



# AURORA

## STAND-ALONE POST OUTDOOR GAS GRILLS

A430s (IN-GROUND AND PATIO MOUNT)

### INSTALLATION INSTRUCTIONS AND OWNER'S MANUAL

**INSTALLER:** Leave these instructions with consumer.  
**CONSUMER:** Retain for future reference.



A430s Patio mount w/ digital thermometer shown

**IMPORTANT:** READ THESE INSTRUCTIONS CAREFULLY BEFORE STARTING INSTALLATION OR USE.

### SAFETY AND WARNING CODES

#### **⚠ DANGER:**

##### **IF YOU SMELL GAS:**

1. Shut off the gas to the appliance.
2. Extinguish any open flame.
3. Open lid.
4. If odor continues, keep away from the appliance and **immediately** call your gas supplier or the fire department.

#### **⚠ WARNING:**

1. Do not store or use gasoline or other flammable vapors and liquids in the vicinity of this or any other appliance.
2. An LP cylinder not connected for use shall not be stored in the vicinity of this or any other appliance.

#### **⚠ WARNING:**

Improper installation, adjustment, alteration, service, or maintenance can cause injury or property damage. For proper installation, refer to the installation instructions. For assistance or additional information, consult a qualified professional installer, service agency, or the gas supplier.

**CODE AND SUPPLY REQUIREMENTS:** This grill must be installed in accordance with local codes and ordinances, or, in the absence of local codes, with either the latest *National Fuel Gas Code (ANSI Z223.1/NFPA 54)*, and *Natural Gas and Propane Storage and Handling Installation Code (CSA-B149.1)*.

This appliance and its dedicated manual shutoff valve must be disconnected from the gas-supply piping system when testing the system at pressures in excess of ½ psig (3.5 kPa).

This appliance must be isolated from the gas-supply piping system by closing its dedicated manual shutoff valve during any pressure testing of the gas-supply system at pressures up to and including ½ psig (3.5 kPa).

All electrical outlets in the vicinity of the grill must be properly grounded in accordance with local codes, or, in the absence of local codes, with the *National Electrical Code, ANSI/NFPA 70*, or the *Canadian Electrical Code, CSA C22.1*, whichever is applicable.

Keep all electrical-supply cords and fuel-supply hoses away from any heated surface.

**Proper operation of your grill requires prompt and periodic maintenance. See the CARE & CLEANING section for details.**



G

US

Certified to:

ANSI Z21.58b-2012  
CSA 1.6b-2012

11-093

# - INSTALLATION INSTRUCTIONS ET MANUEL DU PROPRIÉTAIRE -

## GRIL EXTÉRIEUR DE GAZ

**IMPORTANT: LISEZ CES INSTRUCTIONS SOIGNEUSEMENT AVANT DE COMMENCER L'INSTALLATION OU L'UTILISATION**

### SÛRETÉ ET CODES D'AVERTISSEMENT

#### **▲ DANGER:**

##### **SI VOUS SENTEZ LE GAZ :**

1. Coupez le gaz à l'appareil.
2. Éteignez-vous n'importe quelle flamme nue.
3. Ouvrez le couvercle si équipé d'un four.
4. Si l'odeur continue, gardez loin de l'appareil et appelez immédiatement votre département de fournisseur ou de feu de gaz.

#### **CONDITIONS DE CODE ET D'APPROVISIONNEMENT:**

Ce gril doit être installé selon des codes et des ordonnances locaux, ou, en l'absence des codes locaux, avec l'un ou l'autre le plus défunt *Code national de gaz de carburant* (norme ANSI Z223.1/NFPA 54), et *Stockage de gaz naturel et de propane et manipulation du code d'installation* (CSA-B149.1).

Cet appareil et ses différents robinets d'isolement doivent être démontés du gaz-fournissent le système sifflant en examinant le système aux pressions au-dessus du ½ psig (kPa 3.5).

Cet appareil doit être isolé dans gaz-fournissent le système sifflant par fermeture que ses différents robinets d'isolement manuels pendant tous les essais sous pression du gaz-fournissent le système aux pressions jusques et y compris le ½ psig (kPa 3.5).

- Ce gril est pour utilisation à l'extérieur seulement. Si l'appareil est entreposé à l'intérieur, enlever les bouteilles et les laisser à l'extérieur.
- Ne pas ranger le gril immédiatement après l'avoir utilisé. le laisser refroidir avant de le déplacer ou de la ranger. Le non respect de cette mesure de sécurité pourrait entraîner un incendie causant des dommages à la propriété, des blessures ou la mort.
- Ne pas utiliser cet appareil sous une surface combustible.
- Ne pas utiliser cet appareil sous un auvent. Le non respect de cette mesure de sécurité pourrait entraîner un incendie ou des blessures.
- Dégagement minimal entre les parois latérales et l'arrière de l'appareil et la construction combustible (45.7 cm à partir des parois latérales et 45.7cm à partir de l'arrière).
- Le régulateur de pression de gaz prévu avec cet appareil de cuisson à gaz pour l'extérieur doit être utilisé. Ce régulateur est réglé pour une pression de sortie de 5 pouces de colonne de l'eau pour le gaz naturel, et 10 pouces pour le propane.
- LE RÉGULATEUR INCLUS D'APPAREILS EST ÉVALUÉ POUR LE MAXIMUM DE 1/2 (LIVRES PAR POUCE CARRÉ). SI VOTRE OFFRE DE GAZ EST 1/2 PLUS GRAND QUE (LIVRES PAR POUCE CARRÉ), UN RÉGULATEUR ADDITIONNEL DOIT ÊTRE INSTALLÉ AVANT LE GRIL. VOIR LA SECTION DE CONDITIONS

#### **▲ AVERTISSEMENT:**

1. Ne stockez pas ou n'employez pas l'essence ou d'autres vapeurs et liquides inflammables à proximité de ceci ou d'aucun autre appareil.
2. Un cylindre de propane non relié pour l'usage ne sera pas stocké à proximité de ceci ou d'aucun autre appareil.

#### **▲ AVERTISSEMENT:**

L'installation inexacte, l'ajustement, le changement, le service, ou l'entretien peuvent causer des dommages ou des dégâts matériels. Référez-vous à ce manuel. Pour l'aide ou l'information additionnelle, consultez un installateur professionnel qualifié, l'agence de service, ou le fournisseur de gaz.

Toutes les sorties électriques à proximité du gril doivent être correctement fondues selon des codes locaux, ou en l'absence de local code, avec le code électrique national, ANSI/NFPA 70, ou le code électrique canadien, CSA C22.1, celui qui est applicable.

Maintenez tout électrique-fournissent des cordes et carburant-fournissent des tuyaux partis de n'importe quelle surface de chauffage.

#### **D'OFFRE DE GAZ POUR LA PRESSION APPROPRIÉE D'OFFRE DE GAZ.**

- Ne couvrez jamais la surface entière de cuisine ou de gril de gauffreuses ou de casseroles. La surchauffe se produira et les brûleurs ne seront pas très performants quand la chaleur de combustion est emprisonnée au-dessous de la surface à cuire.
- Ne pulvérisez jamais l'eau sur une unité chaude de gaz, comme ceci peut endommager des composants de porcelaine ou de fer de fonte.
- Une fuite de GPL peut causer un incendie ou une explosion si enflammée entraînant des blessures corporelles graves ou la mort.
- Communiquez avec le fournisseur de GPL pour les réparations ou pour disposer de qules bouteille ou du GPL non utilisé.

**Certifié à la norme: ANSI Z21.58b-2012 / CSA 1.6b-2012**

**INSTALLATEUR : Laissez ces instructions avec le consommateur.  
CONSOMMATEUR : Maintenez pour la future référence.**

# CONTENTS

## GETTING STARTED

ELECTRICAL SAFETY .....	3
REPLACEMENT PARTS LIST .....	4
MODEL SPECIFICATIONS .....	6
<i>MODEL SPECIFICATIONS TABLE</i> .....	6
<i>POST PATIO MOUNT GRILL DIMENSIONS TABLE</i> .....	6
<i>IN-GROUND POST GRILL DIMENSIONS TABLE</i> .....	7
<i>POST GRILL WIRING DIAGRAM</i> .....	8
GRILL MAINTENANCE AND SAFETY INFORMATION .....	9
<i>ELECTRICAL CONNECTIONS</i> .....	9
<i>LIGHT SWITCH</i> .....	9
INSTALLATION REQUIREMENTS .....	10
<i>OVERHEAD CONSTRUCTION REQUIREMENTS (if applicable)</i> .....	10
<i>SIDE AND REAR WALL CLEARANCES</i> .....	10
<i>ENSURE PROPER COMBUSTION AIR AND COOLING AIRFLOW</i> .....	11
<i>EXHAUST REMOVAL</i> .....	11
<i>GAS SUPPLY PLUMBING REQUIREMENTS</i> .....	11
PROPANE SAFETY INFORMATION .....	12
<i>WARNING</i> .....	12
<i>INSTALLATION SAFETY GUIDELINES</i> .....	12
OPERATING THE UNIT SAFELY AND CORRECTLY .....	12
SAFE USE & MAINTENANCE OF PROPANE GAS CYLINDERS .....	13

## INSTALLATION

PATIO MOUNT INSTALLATION .....	15
IN-GROUND POST INSTALLATION .....	17
FLAVOR GRID & RIGID SHELF INSTALLATION .....	20

## USE, CARE, & SERVICE

IDENTIFICATION OF GRILL CONTROLS .....	21
LIGHTING (IGNITION) INSTRUCTIONS .....	23
<i>ELECTRONIC LIGHTING</i> .....	23
<i>MANUAL LIGHTING</i> .....	23
<i>SETTING THE TIMER</i> .....	23
<i>SHUTTING OFF THE UNIT</i> .....	23
OPTIONAL DIGITAL THERMOMETER .....	24
<i>DEFAULT SCREEN</i> .....	24
<i>MENU SCREEN</i> .....	25
OPTIONAL ROTISSERIE .....	27
OPTIONAL INFRARED BURNER OPERATION .....	28
ACCESSORIES .....	29
FIRE MAGIC® DRIP TRAY .....	30
CARE & CLEANING .....	31
REPLACING HALOGEN BULBS .....	32
CONVERT GAS TYPE / CHECK BURNER ORIFICES .....	33
BURNER AIR SHUTTER ADJUSTMENT .....	35
CONTROL PANEL REMOVAL .....	37
NOTES PAGE .....	38
TROUBLESHOOTING .....	39
WARRANTY .....	40

## ELECTRICAL SAFETY

To protect against electric shock, do not immerse cord or plugs in water or other liquid.

Unplug from the outlet when not in use and before cleaning. Allow to cool before putting on or taking off parts.

Do not operate any outdoor cooking gas appliance with a damaged cord, plug, or after the appliance malfunctions or has been damaged in any manner. Contact the manufacturer for repair.

Do not let the cord hang over the edge of a table or touch hot surfaces.

Do not use an outdoor cooking gas appliance for purposes other than intended.

When connecting, first connect plug to the outdoor cooking gas appliance then plug appliance into the outlet.

**Use only a properly wired and inspected 120VAC (15 AMP minimum) Ground Fault Circuit Interrupter (GFCI) GROUNDED 3-wire receptacle with this outdoor cooking gas appliance.**

Never remove the grounding plug or use with an adapter of 2 prongs.

Use only extension cords with a 3 prong grounding plug, rated for the power of the equipment, and approved for outdoor use with a W-A marking.

# REPLACEMENT PARTS LIST

**IMPORTANT**  
Remove all packing material and discard prior to lighting.

To order replacement parts, contact your local Fire Magic® dealer.

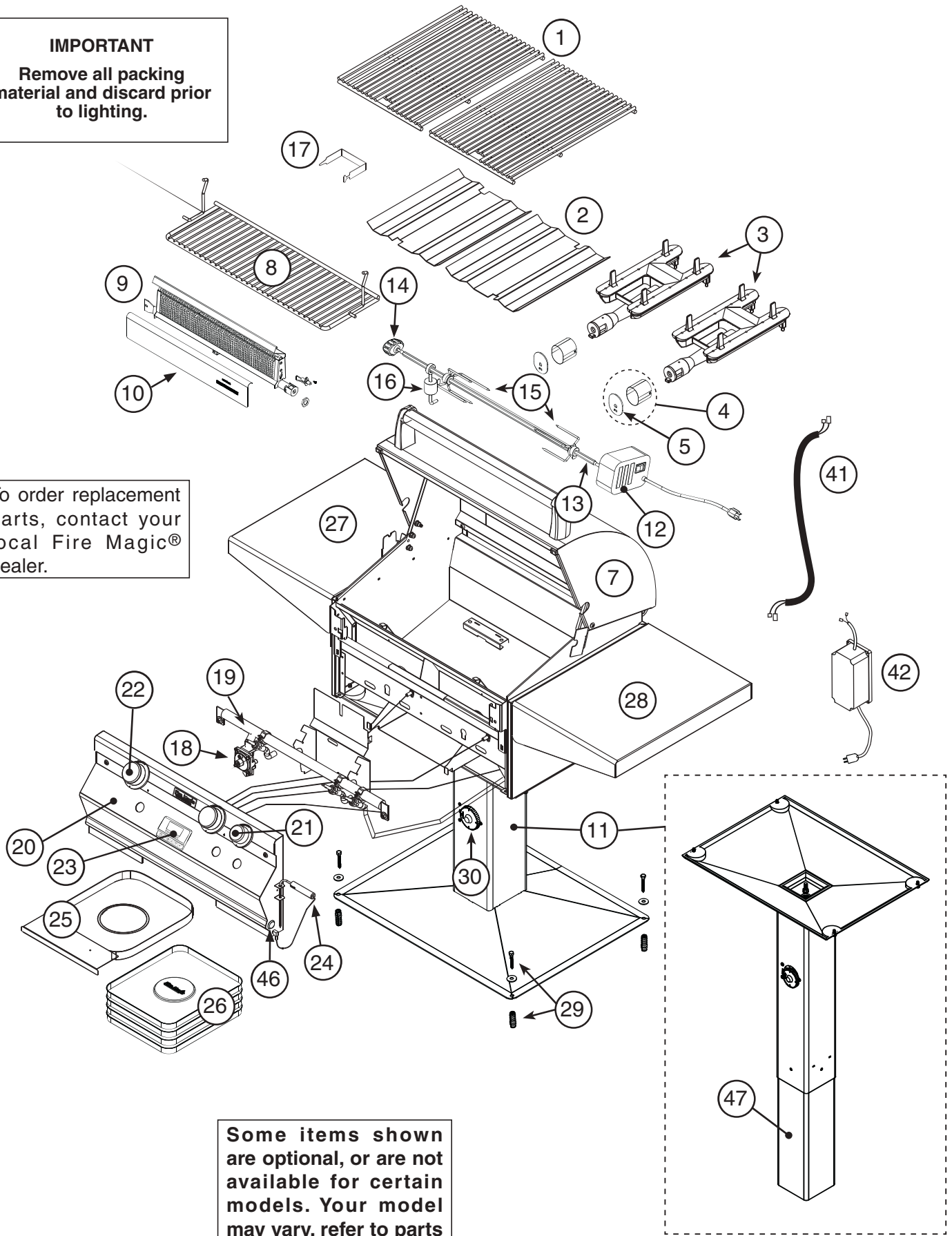

Some items shown are optional, or are not available for certain models. Your model may vary, refer to parts table.

## REPLACEMENT PARTS LIST (cont.)

Item	Description	A430s	
		Part No.	Qty.
1.	Stainless cooking grid (set of 2)	23542-S-2	1
2.	Flavor grid (set of 2)	3063-S-2	1
3.	Main burner	3042-50	2
4.	Heatshield kit	24177-05	2
5.	Silicone gasket	24177-06	2
6.	Infrared burner *‡	3060	1
7.	Oven lid	23729-53	1
or	Oven lid w/ oven thermometer	23729-55	1
8.	Warming rack*	3672S-M	1
9.	Back burner*	24130-11H	1
10.	Back burner cover*	24148-010	1
11.	Patio base w/ hardware *†	24330-31	1
or	In-ground base w/ hardware *†	24330-32	1
12.	Rotisserie motor*	3600-02	1
13.	Rotisserie rod*	3603-30	1
14.	Rotisserie knob*	24187-16	1
15.	Meat holder (pair)*	3613	1
16.	Counterbalance*	3620E	1
17.	Grid lifter	3519	1
18.	Convertible regulator	PR-4	1
19.	Valve manifold w/ back burner	24130-22	1
or	Valve manifold w/o back burner	24130-28	1
20.	Control panel w/ back burner, w/ digital thermometer	24130-45	1
or	Control panel w/ back burner, w/o digital thermometer	24130-47	1
or	Control panel w/o back burner, w/ digital thermometer	24130-46	1
or	Control panel w/o back burner, w/o digital thermometer	24130-48	1
21.	Small knob *	3016	1
22.	Large knob	3015	2

Item	Description	A430s	
		Part No.	Qty.
23.	Digital thermometer	24180-12H	1
or	Oven hood thermometer ‡	23305	1
24.	Meat probe *	24187-14S	1
25.	Drip tray	3084	1
26.	Drip tray liner (set of 4)	3557	1
27.	Rigid shelf (left)	24330-017L	1
28.	Rigid shelf (right)	24330-017R	1
29.	Patio mount hardware kit (if applicable)	24330-25	1
30.	Timer valve (1 hour)	3092A	1
31.	Propane regulator / hose assy. *‡	5110-07	1
or	Natural Gas QD hose *‡	5110-03	1
32.	Wire harness assembly‡	24177-28	1
33.	Back burner electrode*‡	4199-52	1
34.	Main burner electrode‡	3199-72	2
35.	Natural gas orifice(s)‡	3001-42-2	1
36.	Natural back burner gas orifice(s)‡	3001-52-1	1
37.	Propane gas orifice(s)‡	3001-54-2	1
38.	Propane back burner gas orifice(s)‡	3001-59-1	1
39.	Fire Magic® cookbook‡	3595	1
40.	Thermometer wire harness *‡	24177-25	1
41.	Wire harness extension	24182-53	1
42.	Power supply box w/ connector	24177-12	1
43.	<b>12V / 10 watt halogen light bulb ‡</b>	24187-15	2
44.	Light lens ‡	24187-26	2
45.	Lamp assembly ‡	24187-28	2
46.	Light switch	24182-46	1
47.	In-ground post extension only *†	24330-33	1
48.	Backburner flex connector *‡	3030-01	1
49.	Flash tube (left) ‡	24187-29	1
50.	Flash tube (right) ‡	24187-35	1

\* If equipped

† For replacement only (not conversion)

‡ Not shown



# MODEL SPECIFICATIONS

## MODEL SPECIFICATIONS TABLE

Table 1		A430s
Main burner quantity		2
N/P orifice drill size		#42 / #54
Backburner (if equipped)		#52 / #59
N/P orifice drill size		#49 / #56
Infrared searing burner (if equipped)		#49 / #56
N/P orifice drill size		#49 / #56
Input electrical requirements	<b>120VAC / 15 AMP minimum / 60 Hz / GFCI outlet</b>	
Oven lights rating	<b>12V / 10 watt halogen bulb</b>	

## POST PATIO MOUNT GRILL DIMENSIONS TABLE

Height			Width		Depth	
Floor to top (with oven)		Floor to top of shelf (C)	Left to right		Front to back	
Open (A)	Closed (B)		Post base (D)	Shelves (E)	Post base (F)	Maximum outer (G)
57"	50"	37"	26"	55 3/4"	19 1/4"	25 3/4"

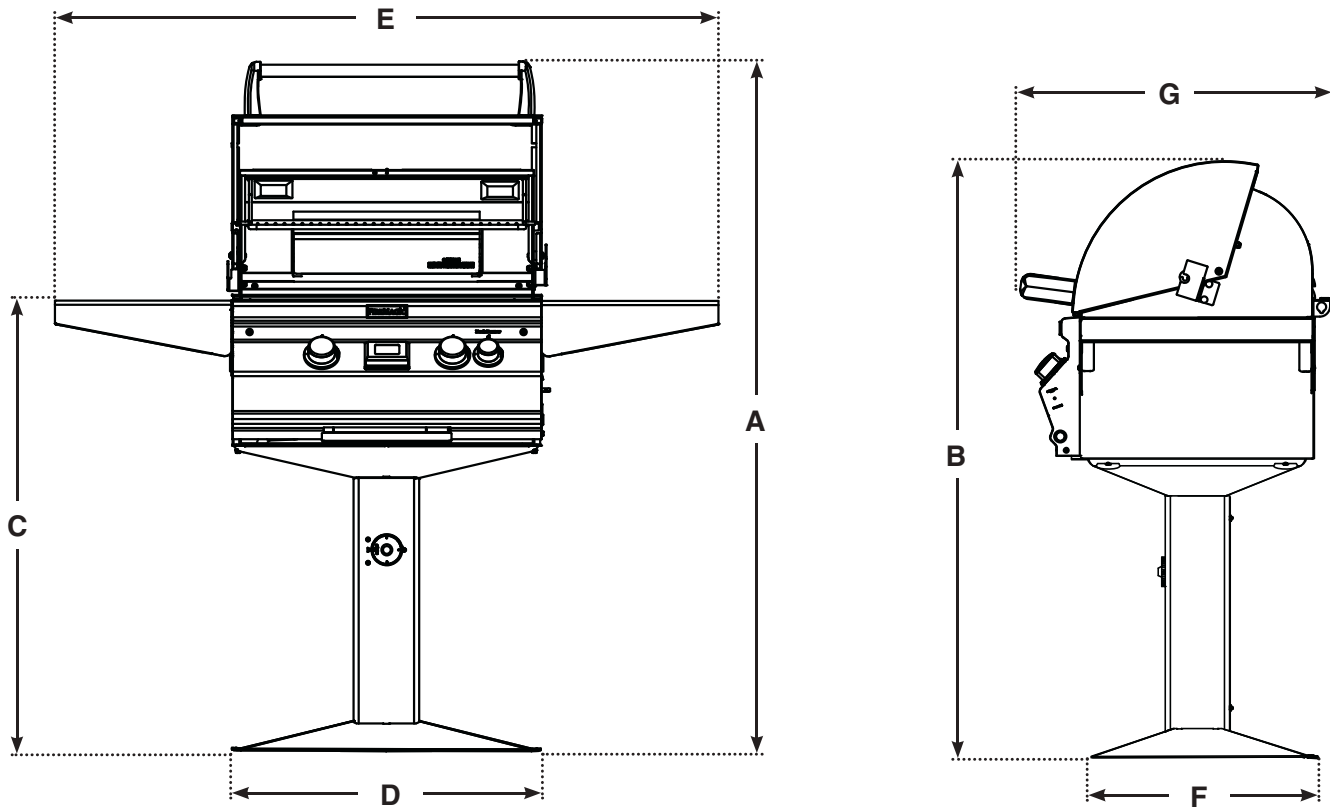

Fig. 6-1

## MODEL SPECIFICATIONS (cont.)

### IN-GROUND POST GRILL DIMENSIONS TABLE

Floor to top (with oven)		Height*		Width		Depth			
		Open (H)	Closed (I)	Left to right	Post (L)	Shelves (M)	Post (N)	Maximum outer (O)	
		57"	50"	37"	18"	5 1/2"	55 3/4"	5 1/2"	25 3/4"

\*Note: Height dimensions are approximate from ground level once installed.

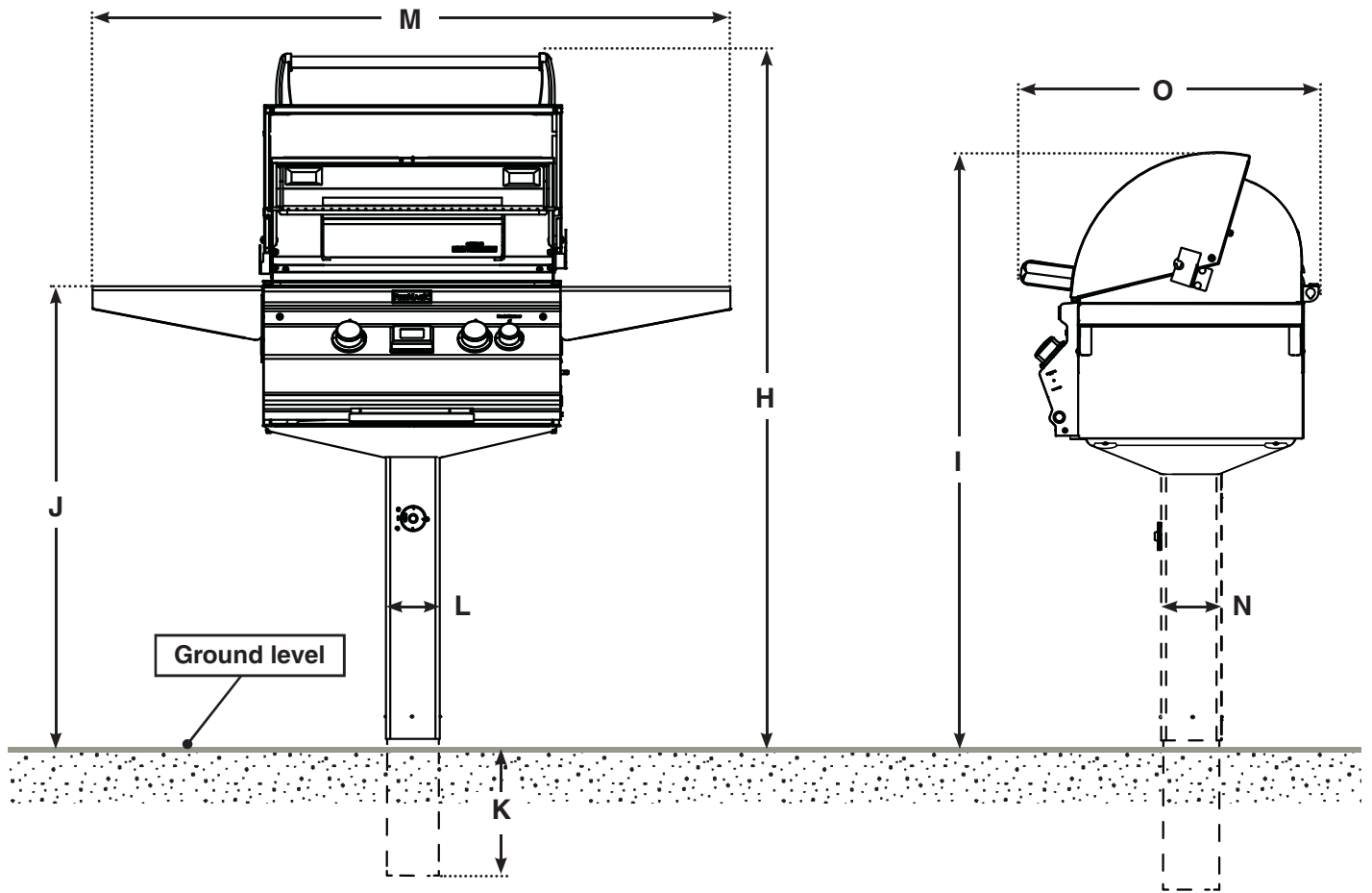
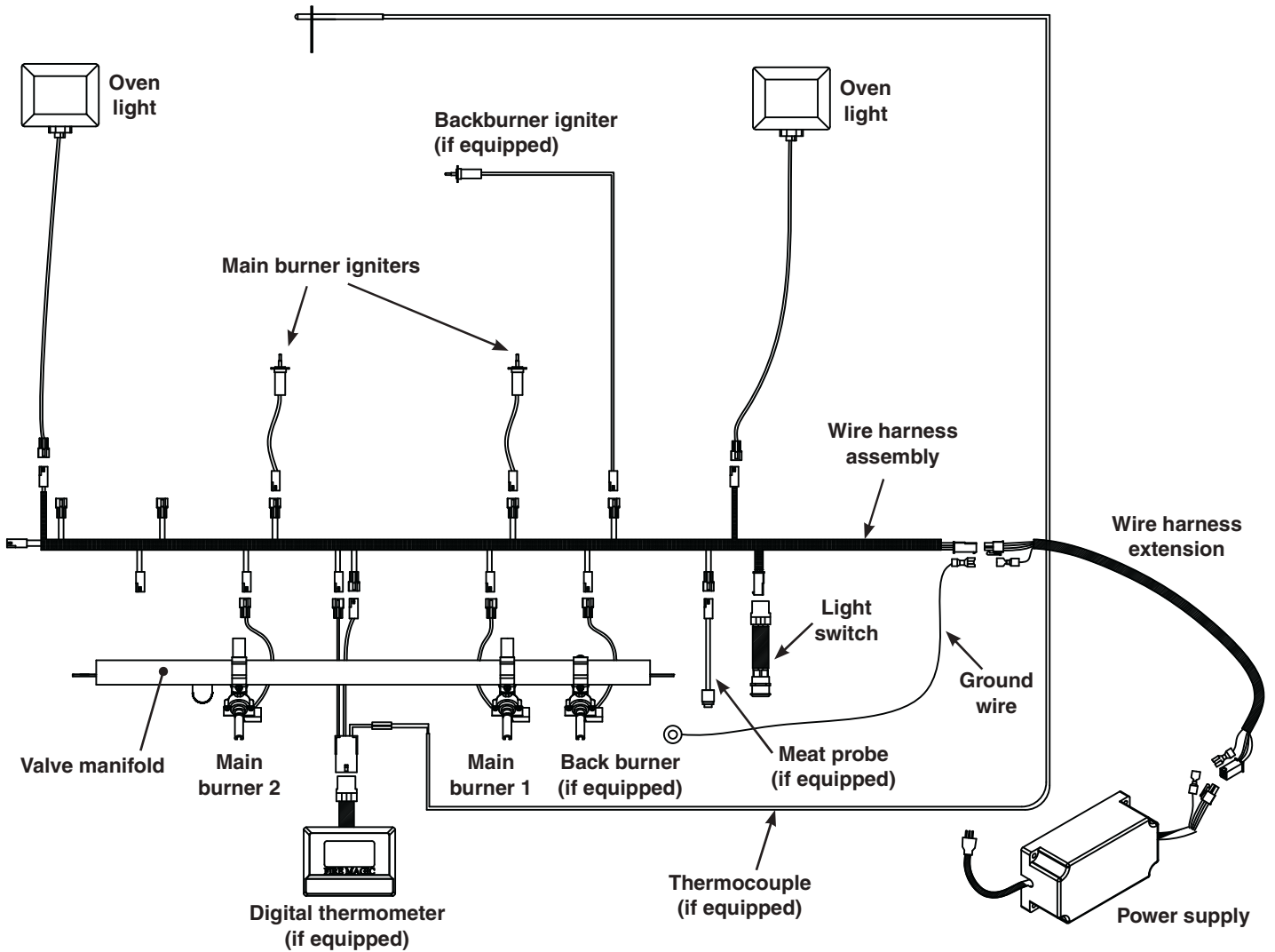

Fig. 7-1

**MODEL SPECIFICATIONS (cont.)**

**POST GRILL WIRING DIAGRAM \***



**\* Model wire diagrams may vary.**

**Note: In addition, a wire diagram specific to your unit can be found affixed to the inside of the control panel.**



## GRILL MAINTENANCE AND SAFETY INFORMATION

1. The outdoor grill and surrounding area **MUST** remain clear of flammable substances such as gasoline, yard debris, wood, etc.
2. The airflow through the vent space located below the control panel must remain unobstructed.
3. **When using propane gas:**
  - a. **The required ventilation openings in the enclosure must be clear of debris. See the PROPANE SAFETY INFORMATION section.**
  - b. **The propane cylinder, regulator, and rubber hose must be in a location not subject to temperature above 125° F (51° C).** A proper flame pattern will ensure safe operation and optimal performance.
4. The flames on each burner burn evenly along the entire burner with a steady flame (mostly blue).
5. If burner flames are not normal, check and clean the orifice and burner/venturi tubes for insects and insect nests. A clogged tube can lead to a fire beneath the grill. A proper flame pattern will ensure safe operation and optimal performance. Adjust the air shutter as needed (see AIR SHUTTER ADJUSTMENT).
5. The in-line gas valve or gas cylinder valve must always be shut OFF when the grill is not in use.
6. The drip collector holes must be clear and unobstructed. Excessive grease deposits can result in a grease fire.
7. The backburner or infrared burner cover must be removed before using the burner.
8. Whenever reconnecting any wires, apply a small amount of dielectric grease to the male connector, then make the connection.

**WARNING: NEVER cover the entire cooking or grill surface with griddles or pans. Overheating will occur, and burners will not perform properly when combustion heat is trapped below the cooking surface.**

**CAUTION: NEVER spray water on a hot gas unit.**

The grill serial identification number is located on the underside of the drip tray handle. It is recommended that the drip tray first be removed and cleaned / emptied of its contents, then turned over to view. The unit rating label is located inside of the control panel.

### ELECTRICAL CONNECTIONS

**A 120VAC (15 AMP minimum) GFCI GROUNDED 3-wire receptacle** (not included) is required within the vicinity of the grill to provide power to the unit.

- **Observe all local codes.**
- **Verify proper polarity of the receptacle.**
- **If an extension cord is used, ensure it is a 3-wire GROUNDED cord that is rated for the power of the equipment, and is approved for outdoor use with a W-A marking. DO NOT use 2-prong adapters.**
- **DO NOT TAMPER WITH THE EXTENSION CORD OR THE UNIT POWER-SUPPLY CORD.**

**Important: ONLY REPLACE THE OVEN LIGHTS WITH 12V / 10WATT HALOGEN BULB(S).**

### LIGHT SWITCH

The light switch is push button operated, and is located on the right side of the control panel (see Fig. 9-1). It controls the power to all lights.

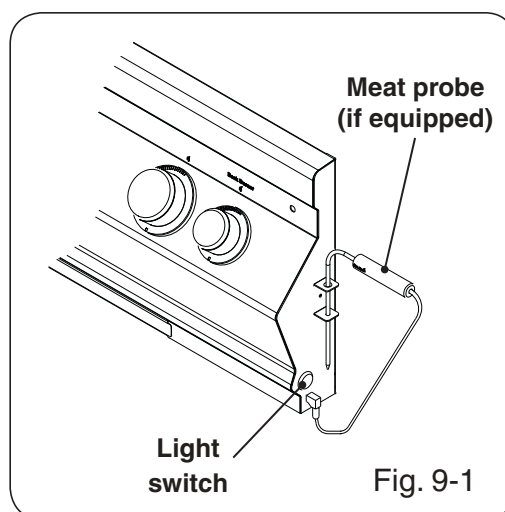

## INSTALLATION REQUIREMENTS

Installation must be performed by a qualified professional service technician.

This grill is designed for outdoor use only. **DO NOT** use this grill inside a building, garage, enclosed area, or under overhead **combustible** construction.

See below and the EXHAUST REMOVAL section on the following page for details on installing under overhead construction.

**DO NOT** use this grill in or on a recreational vehicle or boat.

**Important:** This grill is not insulated. Refer to the information below to ensure all required clearances are met.

**The grill must have a minimum clearance of 18" from combustible materials/items AT ALL TIMES.**

### OVERHEAD CONSTRUCTION REQUIREMENTS (if applicable)

**This outdoor cooking gas appliance shall not be used under overhead combustible construction.**

A minimum clearance of 5 feet is required between the countertop and the construction above (Fig. 10-1).

### SIDE AND REAR WALL CLEARANCES

For the minimum clearances between the grill and any side or rear walls, your setup must fall within one (or more) of the following:

#### A. Clearance between grill and strictly non-combustible wall (i.e. brick wall, see Fig. 10-2)

- The grill **must** have a minimum of 4" right, left, and rear clearance from any non-combustible wall. (To allow for proper ventilation and prevent dangerous overheating.)

#### B. Clearance between grill and combustible wall

- The grill **must** have a minimum of 18" right, left, and rear clearance from any combustible wall (see Fig. 10-4).

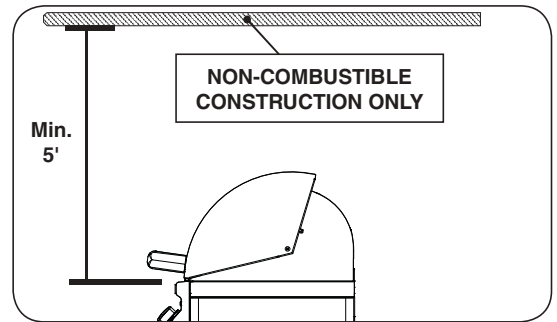

Fig. 10-1 Overhead requirements

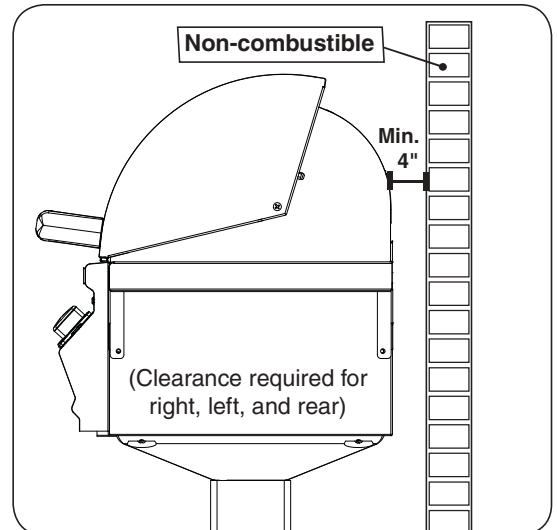

Fig. 10-2 Clearance 'A' Diagram

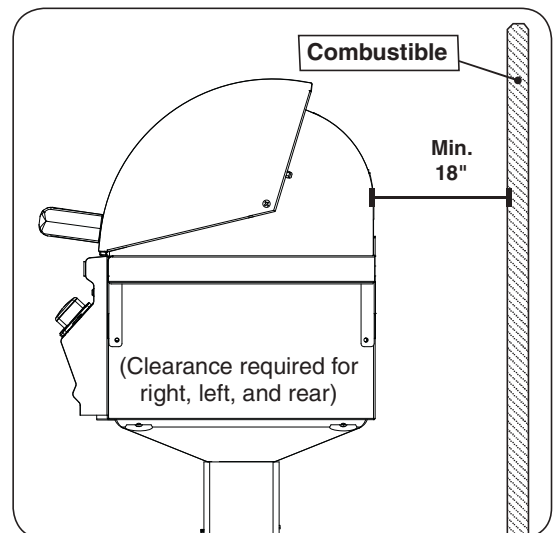

Fig. 10-3 Clearance 'B' Diagram

## INSTALLATION REQUIREMENTS (cont.)

The control panel **MUST** remain removable for servicing and air shutter adjustment (see PARTS LIST).

### ENSURE PROPER COMBUSTION AIR AND COOLING AIRFLOW

Proper airflow (Fig. 11-1) **MUST** be maintained for the grill to perform as it was designed. If airflow is blocked, overheating and poor combustion will result. Do not block the 1" front air inlet along the bottom of the control panel or more than 75% of the cooking grid surface with pans or griddles.

**Note:** The 1" (2.5 cm) front air space also allows access to the drip tray.

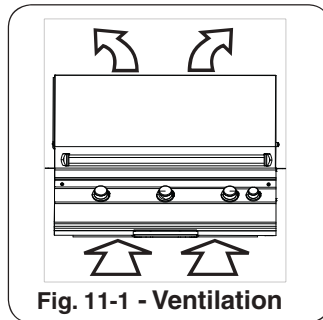

### EXHAUST REMOVAL

If the grill is installed under an overhead structure, **it must be constructed of non-combustible material.** An exhaust hood is recommended. See below.

#### When using an exhaust hood:

The cooking grid area must be covered by an exhaust hood (with a vent) larger than the cooking surface. Refer to manufacturer specifications. An exhaust fan with a rating of 1,000 CFM (cubic feet per minute) (472 liters per second) or more may be necessary to effectively remove smoke and other cooking by-products from the area under the hood. **RHP Vent Hoods are available, contact your local dealer.**

**THIS UNIT MUST NOT BE LOCATED IN A FULLY ENCLOSED AREA OF ANY KIND.**

**CAUTION:** Wind blowing into or across the rear oven lid vent (Fig. 11-2) can cause poor performance and/or dangerous overheating. Orient the grill so that the prevailing wind blows toward the front of the grill (Fig. 11-3).

### GAS SUPPLY AND MANIFOLD PRESSURES:

For **natural gas** - normal 7" (17.78 cm) water column (w.c.), minimum 5" (12.7 cm), maximum 10 1/2" (26.7 cm). For **propane gas** - normal 11" w.c., minimum 10" (25.4 cm), maximum 13" (33 cm).

### INCORRECT

Rear oven lid vent



**YOU MUST PROTECT REAR OVEN VENT FROM PREVAILING WIND**

Fig. 11-2

### CORRECT



**PLACE GRILL SO PREVAILING WIND BLOWS TOWARD FRONT OF GRILL**

Fig. 11-3

### GAS SUPPLY PLUMBING REQUIREMENTS

For natural gas or a household propane system, rigid 1/2", or 3/4" black steel pipe, or local code approved pipe, is required to conduct the gas supply to the unit. An outdoor approved flexible connector can be used to connect your household gas supply to the grill. **DO NOT use a rubber hose within the enclosure for the grill.** Apply only joint compounds that are resistant to all gasses on all male pipe fittings. Make sure to tighten every joint securely.

**Note:** If 1/2" pipe is used with **natural gas**, it should be no longer than 20'.

**Important:** **A shut-off valve (not included) in the gas line is required.** It provides for safety when the unit is not in use and for convenient maintenance and repair. It must be installed within 6 feet of the unit. Use a pipe joint compound resistant to all gasses on all male fittings except flare fittings.

## PROPANE SAFETY INFORMATION

**WHEN OPERATING THIS APPLIANCE WITH PROPANE, ALL INSTRUCTIONS AND WARNINGS MUST BE OBSERVED. FAILURE TO DO SO MAY RESULT IN A FIRE OR EXPLOSION CAUSING SERIOUS INJURY OR DEATH.**

### WARNING

**THIS APPLIANCE MUST BE INSTALLED AND OPERATED ACCORDING TO THE INFORMATION BELOW. FAILURE TO PROPERLY VENT THE PROPANE TANK MAY RESULT IN A FIRE OR EXPLOSION CAUSING SERIOUS INJURY OR DEATH.**

When using **propane gas**:

- **Propane gas** (also known as **L.P. gas**) is heavier than air and will accumulate or pool in an inadequately vented area or recessed area.
- A leaking gas connection or valve unintentionally left open will create a hazard.
- If a pool of **propane gas** is ignited, an explosion will occur. Adequate venting at the floor level of the propane tank eliminates this danger.
- DO NOT store a spare propane-gas cylinder near the unit.

### **INSTALLATION SAFETY GUIDELINES**

**THIS UNIT MUST BE INSTALLED IN SUCH A MANNER THAT THE AREA AROUND THE UNIT AND PROPANE TANK REMAIN CLEAR AND FREE OF ALL OBSTRUCTIONS AT ALL TIMES AND DURING ALL WEATHER CONDITIONS.**

**The gas cylinder, regulator, and rubber hose must be in a location not subject to temps. above 125° F (51° C).**

**WHEN A PROPANE CYLINDER IS INSTALLED, THE GUIDELINES FOUND IN THE **SAFE USE & MAINTENANCE OF PROPANE GAS CYLINDERS** SECTION MUST BE FOLLOWED.**

## OPERATING THE UNIT SAFELY AND CORRECTLY

Every time you use the unit, **make sure that:**

1. The area around the unit is clear and free from combustible materials, gasoline and flammable vapors/liquids.
2. There is no blockage of the airflow around the unit and propane tank.
3. The hose is inspected (if applicable). See **SAFE USE & MAINTENANCE OF PROPANE GAS CYLINDERS** section.

**DO NOT** store any combustible materials, gasoline, and any other flammable vapors/liquids in the vicinity of the unit. Provide adequate clearance for servicing and operation.

# SAFE USE & MAINTENANCE OF PROPANE GAS CYLINDERS

## IMPORTANT FOR YOUR SAFETY

### READ AND FOLLOW ALL WARNINGS PROVIDED WITH THE PROPANE-GAS CYLINDER.

When operating this appliance with a propane-gas cylinder, these instructions and warnings **MUST** be observed.

**FAILURE TO DO SO MAY RESULT IN A SERIOUS FIRE OR EXPLOSION.**

## CYLINDER/CONNECTOR REQUIREMENTS

- a. Propane-gas cylinders, valves, and hoses must be maintained in good condition and must be replaced if there is visible damage to either the cylinder or valve. If the hose is cut or shows excessive abrasion or wear, it must be replaced before using the gas appliance (see e.).
- b. This unit, when used with a cylinder, should be connected to a standard 5-gallon (20 lb.) propane-gas cylinder equipped with an OPD (Overfill Prevention Device). The OPD has been required on all cylinders sold since October 1, 1998, to prevent overfilling.
- c. Cylinder dimensions should be approximately 12" (30.5 cm) in diameter and 18" (45.7 cm) high. Cylinders must be constructed and marked in accordance with the *Specifications for Propane Gas Cylinders of the U.S. Department of Transportation (D.O.T.)* or the National Standard of Canada, *CAN/CSA-B339, Cylinders, Spheres, and Tubes for Transportation of Dangerous Goods*.
- d. The cylinder used must include a collar to protect the cylinder valve, and the cylinder supply system must be arranged for vapor withdrawal.
- e. The pressure regulator and hose assembly used must match the specification for Type I by *ANSI Z 21.58-2005/CGA 1.6-2005* (see Fig. 13-1).
- f. The propane-gas cylinder valve must be equipped with a cylinder connection coupling device, described as Type I in the standard defined in paragraph e. above. This device is commonly described as an Acme thread quick coupler.
- g. If the propane-gas cylinder comes with a dust plug, place the dust cap on the cylinder valve outlet whenever the cylinder is not in use.

## QUICK COUPLER OPERATION

**To connect the regulator/hose assembly to the propane-gas cylinder valve fitting:** Press the hand nut on the regulator over the Acme thread fitting on the cylinder valve. Turn the hand nut clockwise to engage the threads and tighten until snug.

The use of pliers or a wrench should not be necessary. Only cylinders marked "propane" may be used.

**To disconnect:** Turn the hand nut counterclockwise until detached (Fig. 13-1).

**Important:** Before using the unit, and after each time the cylinder is removed and reattached, check the hose for wear (see a.) and check all connections for leaks. Turn off the unit valves and open the main cylinder valve, then check connections with soapy water. Repair any leaks before lighting the unit.

**CAUTION:** Always turn the propane cylinder main valve off after each use, and before moving the unit and cylinder or disconnecting the coupling. This valve must remain closed and the cylinder disconnected while the appliance is not in use, even though the gas flow is stopped by a safety feature when the coupler is disconnected.

**Carefully** inspect the hose assembly each time before the gas is turned on. A cracked or frayed hose must be replaced immediately.

If the appliance is stored indoors, the cylinder must be disconnected and removed. Disconnected cylinders must be stored outdoors, out of the reach of children, with threaded valve plugs tightly installed, and must not be stored in a building, garage, or any other enclosed area.

## FOR YOUR SAFETY

- a. DO NOT store a spare propane-gas cylinder under or near this appliance.
- b. NEVER fill the cylinder beyond 80-percent full.
- c. IF THE INFORMATION IN a. AND b. IS NOT FOLLOWED EXACTLY, A FIRE CAUSING DEATH OR SERIOUS INJURY MAY OCCUR.

**Fig. 13-1 Type I Acme thread quick coupler**

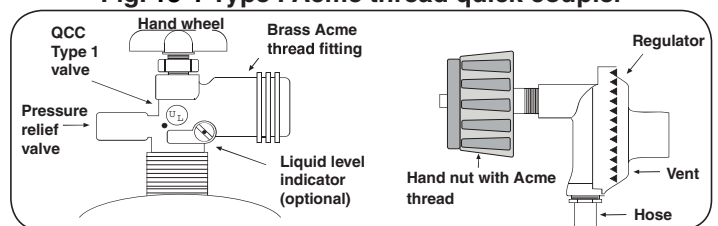



# — UTILISATION SÛRE ET ENTRETIEN DES CYLINDRES DE GAZ DE PROPANE —

## IMPORTANT POUR VOTRE SÛRETÉ

### LISEZ ET SUIVEZ TOUS LES AVERTISSEMENTS ÉQUIPÉS DE VOTRE CYLINDRE DE GAZ DE PROPANE.

En actionnant cet appareil avec un cylindre de gaz de propane ON DOIT observer ces instructions et avertissements.

**LE MANQUE DE FAIRE AINSI PEUT AVOIR COMME CONSÉQUENCE UNE INCENDIE OU UNE EXPLOSION SÉRIEUSE.**

## CYLINDRE ET CONDITIONS ET CARACTÉRISTIQUES DE CONNECTEUR

- Des cylindres et les valves de gaz de propane doivent être maintenus en bon état et doivent être remplacés s'il y a des dommages évidents au cylindre ou à la valve.
- Ce gril, une fois utilisé avec un cylindre, devrait être relié à un gallon de la norme 5 (20lb.) cylindre de gaz de propane équipé d'un OPD (remplissez au-dessus du niveau le dispositif d'empêchement). L'OPD a été exigé sur tous les cylindres vendus depuis octobre 1.1998 pour empêcher le remplissage excessif.
- Les dimensions de cylindre devraient être approximativement 12" (30.5cm) de diamètre et 18" (45.7cm) hauts. Des cylindres doivent être construits et marqués selon les caractéristiques pour des cylindres de gaz de propane du département des ETATS-UNIS du transport (D.O.T.) ou le niveau national du Canada, du CAN/CSA-B339, des cylindres, des sphères et des tubes pour le transport des marchandises dangereuses.
- Le cylindre doit inclure un collier pour protéger la valve de cylindre et le circuit d'alimentation de cylindre doit être assuré le retrait de vapeur.
- Le régulateur de pression et l'ensemble de tuyau utilisé doivent assortir les spécifications pour le type I par ANSI Z 21.58-2005/CGA 1.6-2005 (voir la figue. 14-1).
- La valve de cylindre de gaz de propane doit être équipée d'un dispositif d'accouplement de raccordement de cylindre, décrit comme type I dans la norme définie dans le e. de paragraphe ci-dessus. Ce dispositif est généralement décrit comme coupleur rapide de fil de point culminant.
- Si votre cylindre de gaz de propane vient avec une prise de la poussière, placez le bouchon anti-poussière sur la sortie de valve de cylindre toutes les fois que le cylindre n'est pas en service.

## OPÉRATION DE COUPLEUR RAPIDE

**Pour relier le regulator/hose à l'ajustage de précision de valve de cylindre de gaz de propane:** Serrez l'écrou de main sur le régulateur au-dessus de l'ajustage de précision de fil de point culminant sur la valve de cylindre. Tournez l'écrou de

main dans le sens des aiguilles d'une montre pour engager les fils et pour serrer jusqu'à ce que douilletement. L'utilisation des pinces ou de la clé ne devrait pas être nécessaire. Seulement le propane marqué par cylindres doit être employé.

**Pour débrancher:** Tournez l'écrou de main dans le sens contraire des aiguilles d'une montre jusqu'à isolé (fig. 14-1).

**Important:** Avant d'employer le gril, et ensuite chaque fois que le cylindre est enlevé et rattaché, examinez tous les raccordements pour déceler les fuites. Arrêtez les valves de gril et ouvrez la valve principale de cylindre, puis vérifiez les raccordements avec de l'eau savonneux. Réparez toutes les fuites avant d'allumer le gril.

**ATTENTION:** Tournez toujours la valve principale de cylindre de propane au loin après chaque utilisation, et avant de déplacer le gril et le cylindre, ou débrancher l'accouplement. Cette valve doit rester fermée et le cylindre a débranché alors que l'appareil n'est pas en service, quoique l'écoulement de gaz soit arrêté par un dispositif de sûreté quand le coupleur est débranché.

**Inspectez soigneusement** l'ensemble de tuyau chaque fois avant que le gaz soit allumé. Un tuyau fissuré ou effiloché doit être immédiatement remplacé.

Si l'appareil est stocké à l'intérieur, le cylindre doit être disconnected et a enlevé. Des cylindres Disconnected doivent être stockés dehors, hors de la portée des enfants, avec les prises de valve filetées étroitement installées, et ne doivent pas être stockés dans un bâtiment, le garage, ou n'importe quel autre secteur inclus.

## POUR VOTRE SÛRETÉ

- Ne stockez pas un cylindre de gaz disponible de propane dessous ou ne vous approchez pas de cet appareil.
- Ne remplissez jamais cylindre au delà de 80 pour cent de plein.
- SI L'INFORMATION DANS "A" ET "B" N'EST PAS SUIVIE EXACTEMENT, UN FEU CAUSANT LA MORT OU DES DOMMAGES SÉRIEUX PEUT SE PRODUIRE.

**Fig. 14-1 type coupleur rapide de fil de point culminant d'I**

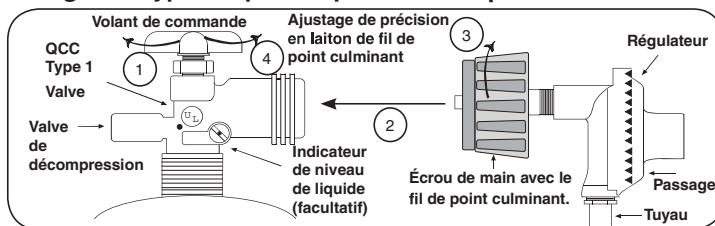



## PATIO MOUNT INSTALLATION

### PREPARE FOR INSTALLATION

Consult a qualified professional installer.

The flex connector can be routed out the back of the post, under the post base, or inside the post. The power supply cord is to be routed out the back.

To gain access to the inside of the post, unscrew and carefully open the access plate on the rear of the post using a medium Phillips-head screwdriver. Retain the screws.

A power supply is pre-mounted to the access plate. For ease of installation, disconnect the power supply from the wire harness extension. Locate the wires coming from the inside of the post to the power supply and carefully disconnect (see Fig. 15-1 and 15-2).

**Important:** Pull from the connectors (not the wires).

### ROUTE POWER SUPPLY CORD

The power cord will need to be routed through the access plate for later connection to a **120VAC (15 AMP minimum) GFCI GROUNDED 3-wire receptacle**.

1. Remove the knock-out disc at the bottom left of the access plate with a large flathead screwdriver. (Insert the screwdriver into the notch provided in the center of the knock-out.)
2. Remove the plastic power cord bushing attached to the power cord.
3. Feed the power cord through the newly created hole.
4. Install the bushing onto the power cord and slide the bushing up against the access plate knock-out hole and snap into place. See Fig. 15-1.

### ROUTE FLEX CONNECTOR

The gas supply line will need to be run to the post install location as appropriate for the desired setup.

**To route flex connector through rear of post:**

1. Remove the knock-out disk at the bottom right of the access plate with a large flathead screwdriver. (Insert the screwdriver into the notch provided in the center of the knock-out.)
2. Remove the plastic grommet (attached to the flex connector) and insert it into the newly created opening. Then route the flex connector through the opening. See Fig. 15-1 and 15-2.

**To route flex connector beneath post base:**

Route the flex connector through the hole found beneath the center of the post base (see Fig. 15-3).

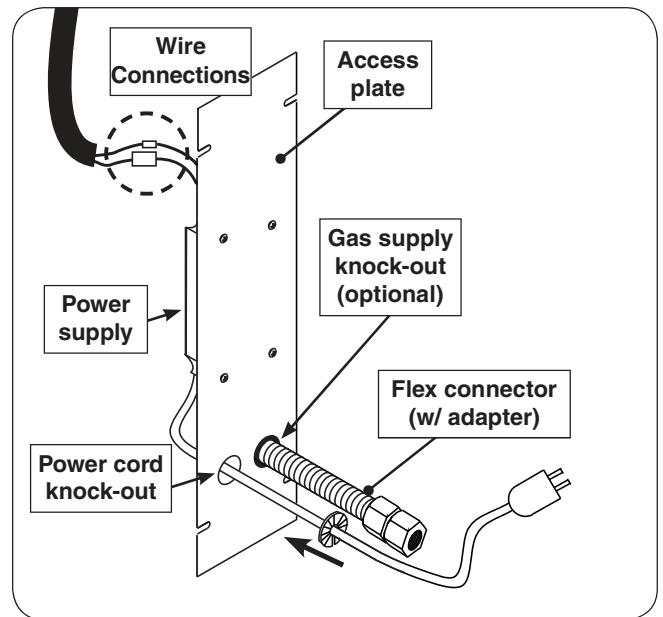

Fig. 15-1 Access plate view & install orientation

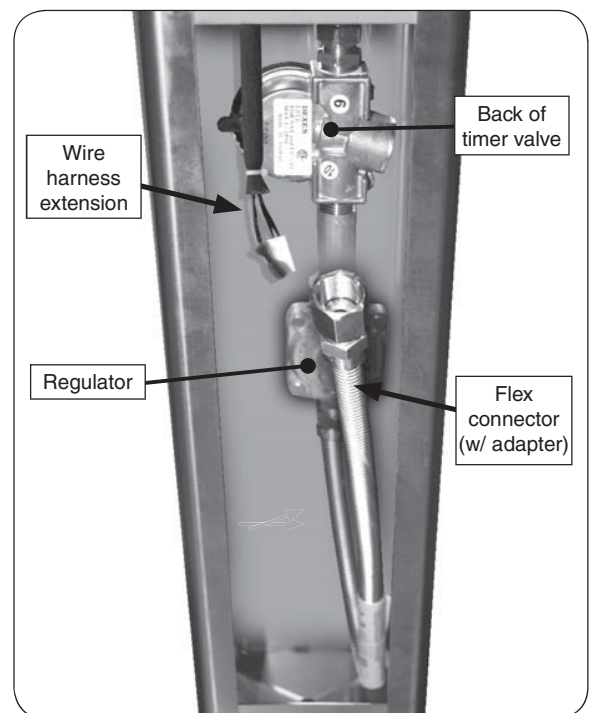

Fig. 15-2 Post interior detail

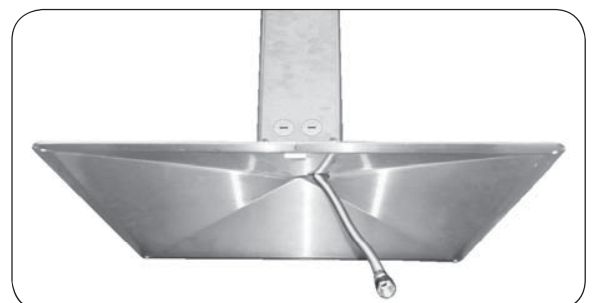

Fig. 15-3 Post base option

## PATIO MOUNT INSTALLATION (cont.)

### CONNECT THE GAS SUPPLY

**For household propane or natural gas units:**

1. Route the flex connector to the gas stub.
2. **Turn OFF the gas supply at the source.**
3. A shut-off valve is required within 6 feet of the unit.

***If shut-off valve is connected to end of gas supply stub:***

- Connect the flex connector to the shut-off valve (see Fig. 16-2). Tighten securely.

***If shut-off valve is installed in-line:***

- Install the supplied flare adapter to the gas supply using a pipe joint compound resistant to all gasses (see Fig. 16-2). Tighten securely.
- Connect the flex connector to the flare adapter (see Fig. 16-2). Tighten securely.

**For propane cylinders:**

For connecting a propane unit to a portable propane tank, read the safety warnings and follow the instructions in the section SAFE USE AND MAINTENANCE OF PROPANE GAS CYLINDERS.

**Important:** An appropriate adapter will be required to connect the existing flex connector to an L.P. regulator/hose assembly.

### LEAK TEST

Turn all burner control knobs to the **OFF** position. Turn the gas supply on. Then carefully check *all* gas connections for leaks with a brush and half-soap/half-water solution before lighting. **NEVER USE A MATCH OR OPEN FLAME TO TEST FOR LEAKS.**

### RECONNECT POWER SUPPLY WIRES

**CAUTION:** IMPROPERLY CONNECTED WIRES WILL CAUSE DAMAGE TO THE GRILL AND MAY RESULT IN PROPERTY DAMAGE AND/OR PERSONAL INJURY.

To **connect the power supply box**, connect the wires coming from the power supply to the wire harness extension as shown in Fig. 16-1.

**Important:** Apply dielectric grease to the male connectors prior to making any wire connections.

### RE-SECURE ACCESS PLATE

Carefully replace the access plate using the four screws, ensuring all interior components are properly oriented inside of the grill. Ensure the power supply cord (and flex connector if applicable) coming out of the rear of the post are properly situated and the plastic bushing/grommet pieces are secure in place.

### CONNECT POWER CORD

Connect the cord coming from the rear access plate to a **120VAC (15 AMP minimum) GFCI GROUNDED 3-wire receptacle**.

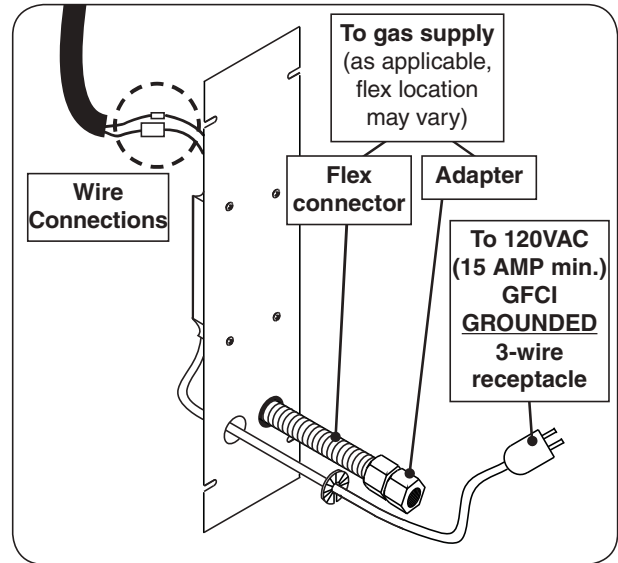

**Fig. 16-1** Connect: Gas, Wires, Plate, Power

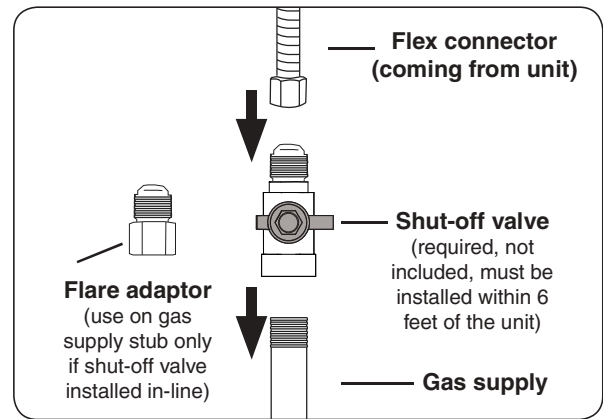

**Fig. 16-2** Connecting to a gas line

### WARNING

#### **Electrical Grounding Instructions:**

**This appliance is equipped with a three-pronged (grounding) plug for your protection against shock hazard and should be plugged directly into a properly grounded three-prong receptacle. Do not cut or remove the grounding prong from this plug.**

### SECURING THE PATIO MOUNT GRILL

**Important:** **BEFORE USE**, the patio mount base must be securely fastened to a stable, level surface to ensure the grill remains fixed and upright at all times.

Locate the patio mount base in the planned grill location and mark the 4 holes. Drill the marked holes to a 1/2" diameter x 1 1/2" depth. Insert the lag shields (see PARTS LIST) into the holes, being sure that they are flush with the ground.

Align the holes on the patio mount base over the lag shields in the ground. Secure the base with the lag screws (see PARTS LIST) using a 7/16" nut driver.

## IN-GROUND POST INSTALLATION

### PREPARE FOR INSTALLATION

Consult a qualified professional installer / licensed contractor.

The in-ground post is designed primarily for installation with a permanent underground gas supply. The power supply cord is to be routed out the back.

To gain access to the inside of the post, unscrew and carefully open the access plate on the rear of the post using a medium Phillips-head screwdriver. Retain the screws.

A power supply is pre-mounted to the access plate. For ease of installation, disconnect the power supply from the wire harness extension. Locate the wires coming from the inside of the post to the power supply and carefully disconnect (see Fig. 17-1 and 17-2).

**Important:** Pull from the connectors (not the wires).

### ROUTE POWER SUPPLY CORD

The power cord will need to be routed through the access plate for later connection to a **120VAC (15 AMP minimum) GFCI GROUNDED 3-wire receptacle**.

1. Remove the knock-out disc at the bottom left of the access plate with a large flathead screwdriver. (Insert the screwdriver into the notch provided in the center of the knock-out.)
2. Remove the plastic power cord bushing attached to the power cord.
3. Feed the power cord through the newly created hole.
4. Install the bushing onto the power cord and slide the bushing up against the access plate knock-out hole and snap into place. See Fig. 17-1.

### ROUTE GAS SUPPLY (UNDERGROUND METHOD)

**Note:** This section addresses an underground gas supply setup. To connect through the rear of the post, reference the ROUTE FLEX CONNECTOR section of PATIO-MOUNT INSTALLATION, and do not perform the steps until after: attaching the extension post, and installing the post / pouring the concrete.

1. After running the underground gas supply line to the planned grill location, dig a hole for the post and extension approximately 18" deep and 10-12" in diameter.

**Note:** Run the gas supply line up from the bottom of the hole (a little off center) so that it reaches to approximately 4" above ground level.

**Note:** The actual depth of the hole should be such that the cooking surface is 34-35" above ground level.

2. Verify that the gas supply line fits through the gas line clearance hole in the bottom of the post (see Fig. 17-3). The clearance hole is the larger of the two holes in the bottom of the post and is off center.
3. Verify that the flex connector coming from the inside of the post will connect properly with the gas supply line.

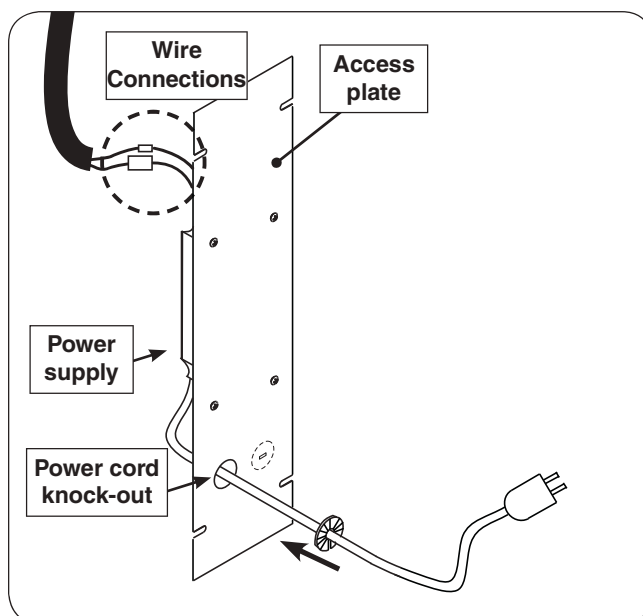

Fig. 17-1 Access plate view & orientation

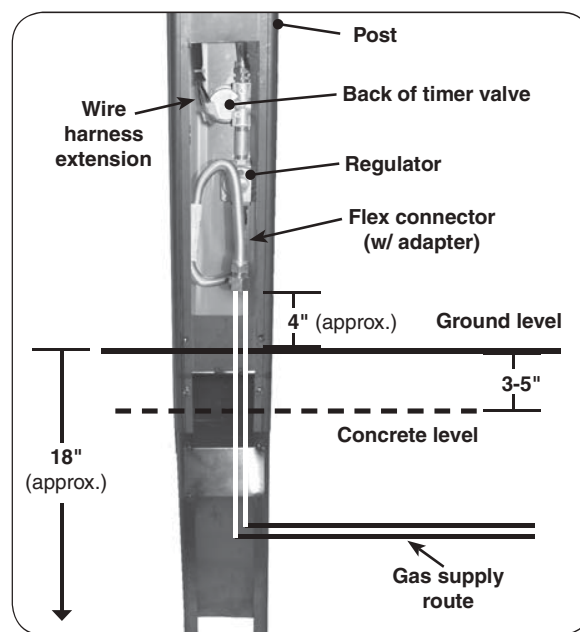

Fig. 17-2 In-ground install orientation

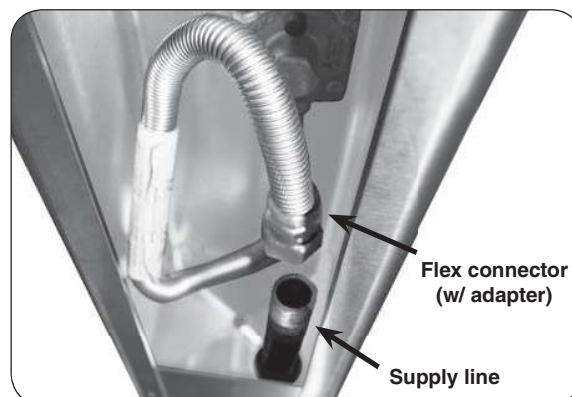

Fig. 17-3 Post interior detail

## IN-GROUND POST INSTALLATION (cont.)

### ATTACH POST EXTENSION

1. Attach the extension to the bottom of the grill post so that the open portion is toward the back of the grill and the five holes in the extension line up with the five (5) weld-nuts in the post (see Fig. 18-1).
2. From outside the joined post and extension, insert one of the  $\frac{1}{4}$  X 20"-5/8 bolts (supplied) into each of the five (5) bolt holes and tighten each using a  $\frac{7}{16}$ " socket driver or wrench (see Fig. 18-2).

**Note:** There is one hole on each side of the post, except the back which has two holes located on either side of the extension opening.

### PLACE POST IN-GROUND & POUR CONCRETE

1. Prepare the concrete to be used for the install.
2. Carefully orient the post over the gas supply line and into the installation hole.

**Important:** Verify that the gas supply line is running up through the post hole, just off center. It must extend high enough to reach the grill gas connection and remain safely above the level of the concrete when poured.

3. Remove the post, then cover the end of the gas supply line with a plastic bag and/or masking tape to avoid getting concrete or other debris in the supply line.
4. Pour the concrete into the hole 3-5" below ground level taking care to protect the gas supply line.
5. While the concrete is still wet, carefully lower the extended grill post into the hole so that the gas supply line slides through the clearance hole in the bottom of the post.
6. Orient the grill per plan, then level the grill and support it so that it remains in position while the concrete dries.

### ROUTE FLEX CONNECTOR (ABOVE GROUND METHOD ONLY)

**Note:** This section addresses an above ground gas supply setup. If connecting underground, skip this section and continue with installation.

The gas supply line will need to be run to the post install location as appropriate for the desired setup.

#### To route flex connector through rear of post:

1. Remove the knock-out disk at the bottom of the access plate with a large flathead screwdriver. (Insert the screwdriver into the notch provided in the center of the knock-out.)
2. Remove the plastic grommet (attached to the flex connector) and insert it into the newly created opening. Then route the flex connector through the opening. See Fig. 18-4.

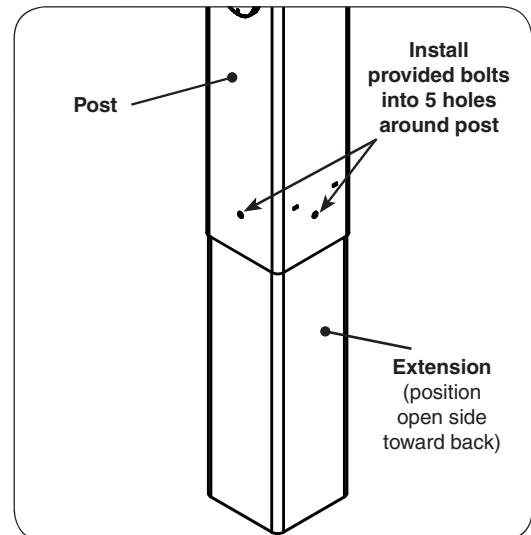

Fig. 18-1 Install extension to post

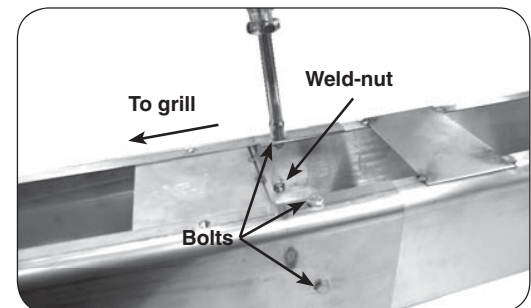

Fig. 18-2 Fasten extension to post

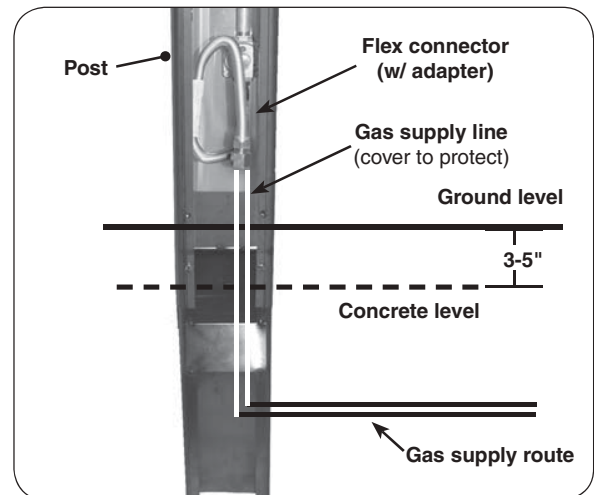

Fig. 18-3 Pour concrete & install post

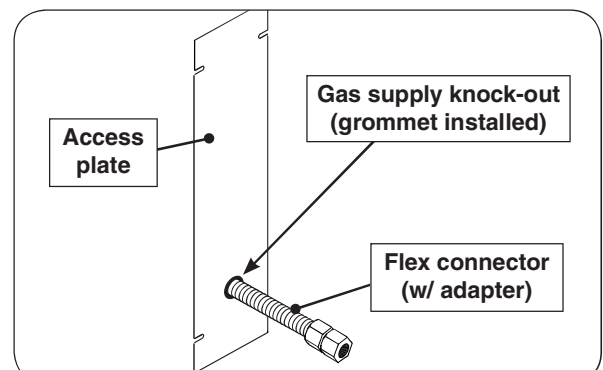

Fig. 18-4 Access plate view & install orientation



## IN-GROUND POST INSTALLATION (cont.)

### CONNECT THE GAS SUPPLY

For household propane or natural gas units:

1. Route the flex connector to the gas stub.
2. Turn OFF the gas supply at the source.
3. A shut-off valve is required within 6 feet of the unit.

**If shut-off valve is connected to end of gas supply stub:**

- Connect the flex connector to the shut-off valve (see Fig. 19-1). Tighten securely.

**If shut-off valve is installed in-line:**

- Install the supplied flare adapter to the gas supply using a pipe joint compound resistant to all gasses (see Fig. 19-1). Tighten securely.
- Connect the flex connector to the flare adapter (see Fig. 19-1). Tighten securely.

For propane cylinders:

For connecting a propane unit to a portable propane tank, read the safety warnings and follow the instructions in the section SAFE USE AND MAINTENANCE OF PROPANE GAS CYLINDERS.

**Important:** An appropriate adapter will be required to connect the existing flex connector to an L.P. regulator/hose assembly.

### LEAK TEST

Turn all burner control knobs to the **OFF** position. Turn the gas supply on. Then carefully check *all* gas connections for leaks with a brush and half-soap/half-water solution before lighting. **NEVER USE A MATCH OR OPEN FLAME TO TEST FOR LEAKS.**

### RECONNECT POWER SUPPLY WIRES

**CAUTION:** IMPROPERLY CONNECTED WIRES WILL CAUSE DAMAGE TO THE GRILL AND MAY RESULT IN PROPERTY DAMAGE AND/OR PERSONAL INJURY.

**To connect the power supply box,** connect the wires coming from the power supply to the wire harness extension as shown in Fig. 19-2.

**Important:** Apply dielectric grease to the male connectors prior to making any wire connections.

### RE-SECURE ACCESS PLATE

Carefully replace the access plate using the four screws, ensuring all interior components are properly oriented inside of the grill. Ensure the power supply cord (and flex connector if applicable) coming out of the rear of the post are properly situated and the plastic bushing/grommet pieces are secure in place.

### CONNECT POWER CORD

Connect the cord coming from the rear access plate to a **120VAC (15 AMP minimum) GFCI GROUNDED 3-wire receptacle.**

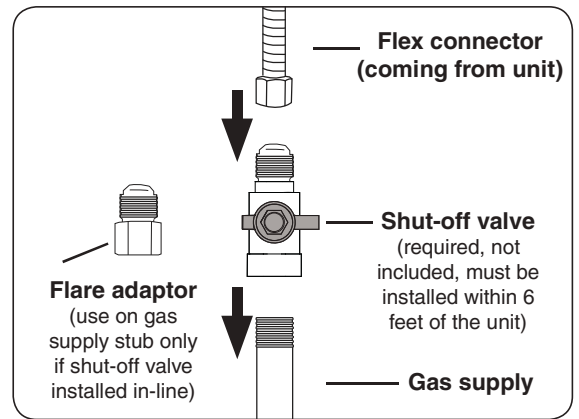

Fig. 19-1 Connecting to a gas line

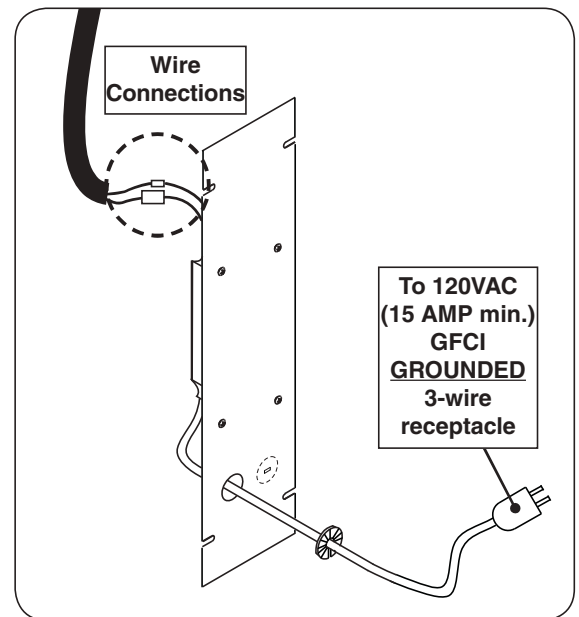

Fig. 19-2 Connect: Wires, Plate, Power

### WARNING

**Electrical Grounding Instructions:**  
This appliance is equipped with a three-pronged (grounding) plug for your protection against shock hazard and should be plugged directly into a properly grounded three-prong receptacle. Do not cut or remove the grounding prong from this plug.

## FLAVOR GRID & RIGID SHELF INSTALLATION

### INSTALL THE FLAVOR GRIDS

Place the flavor grids directly onto the studs on the burners. See Fig. 20-1. The flavor grids allow heat from the burners to be evenly distributed throughout the cooking area. They are stainless steel and will heat and cool quickly, making your grill very responsive to the changes you specify in grill temperature. They are rust resistant and may be cleaned with standard oven cleaners. Some discoloring will be seen with use. This is normal for stainless steel and does not affect the function,

### INSTALL THE RIGID SHELVES

This grill comes with two (2) rigid shelves that must be attached. These can be attached using the four support screws provided and a Phillips-head screw driver.

**Important:** Take caution to not cross-thread when tightening the screws.

1. Hold the shelf inverted so that one of the corner holes in the shelf lines up with the appropriate upper screw hole in the grill.
2. Insert the screw, but do not tighten all the way so that the shelf can be easily rotated around the first screw.
3. Line up the second corner hole in the shelf with the remaining upper screw hole in the grill. Insert a screw and tighten.

**Note:** You may lift the edge of the shelf upward to gain better access during much of the tightening of this screw.

4. Finally, insert the bottom screws on the left and right side of the shelf and securely tighten all screws.

To detach, reverse the process above.

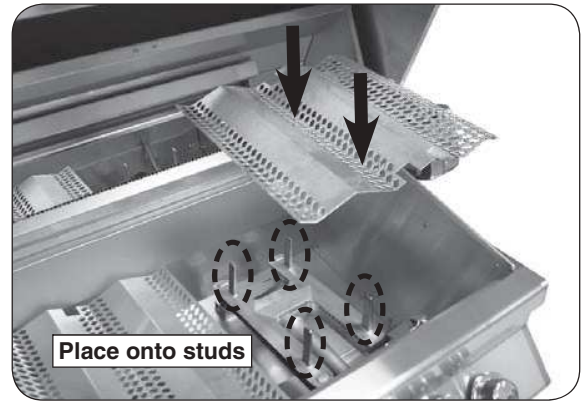

Fig. 20-1 Install flavor grids

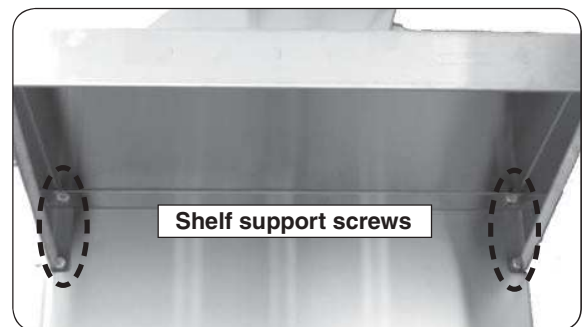
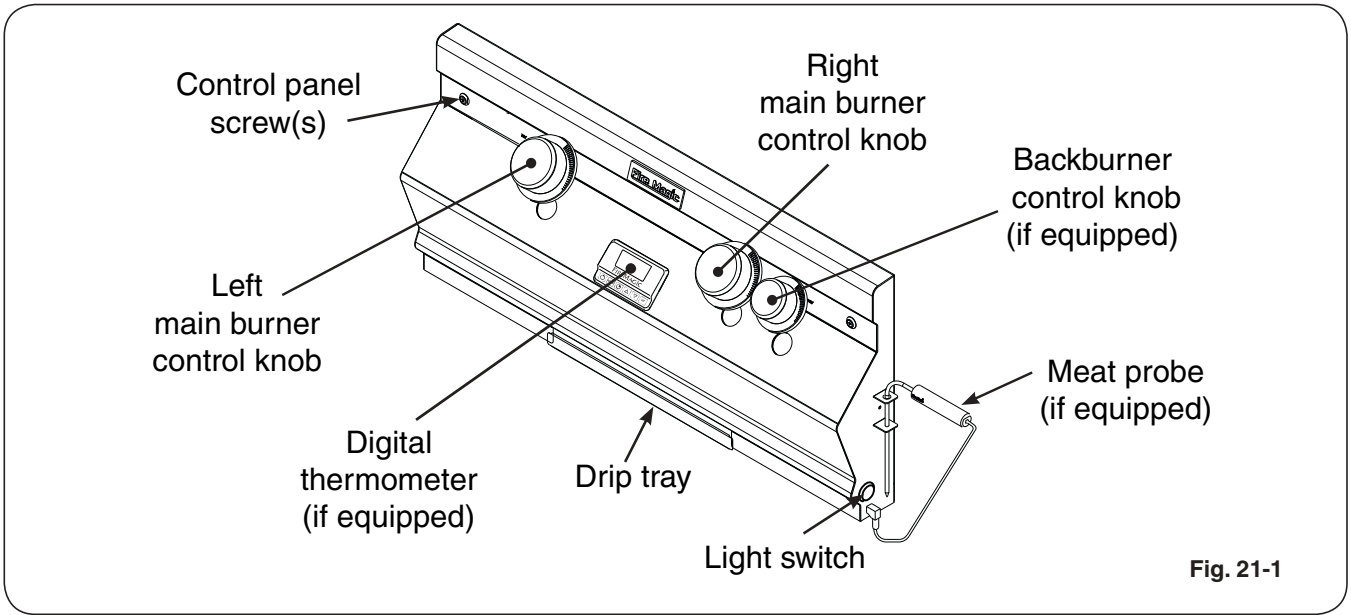

Fig. 20-2 View from under right shelf



## IDENTIFICATION OF GRILL CONTROLS

### A430s controls



## ALLUMAGE DES INSTRUCTIONS (D'ALLUMAGE)

Lisez toutes les instructions avant l'allumage, et suivez ces instructions chaque fois vous lumière le unité.

### ÉCLAIRAGE ÉLECTRONIQUE

**Note:** Le unité doit être relié à la puissance 120VAC pour l'éclairage électronique.

1. Ouvrez les couvercles ou enlevez les couvertures des brûleurs pour être Lit.
2. Tournez tous les boutons de commande de gaz à leurs positions de repos.
3. Allumez le gaz à sa source.

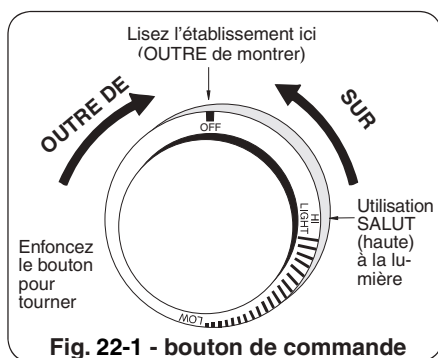

Fig. 22-1 - bouton de commande

4. Placez le bouton de commande de temporisateur au temps de cuisson.
5. Diminuez le bouton de commande désiré pendant 5 secondes, puis, et tout en pressant le tour il dans le sens contraire des aiguilles d'une montre dans la position LÉGÈRE de HI. Une fois que le brûleur s'allume, libérez le bouton.

**ATTENTION :** Si un brûleur ne s'allume pas dans cinq (5) secondes d'allumer le bouton de commande, enfoncez le bouton et tournez-le à la position de repos. ATTENDEZ CINQ (5) MINUTES avant de répéter l'étape 4. Si vous sentez le gaz, suivez les instructions sur la couverture de ce manuel. Si les brûleurs ne s'allument toujours pas après que plusieurs tentatives, se rapportent aux instructions pour l'éclairage manuel.

6. Répétez l'étape 5 pour que chaque brûleur additionnel soit Lit.

### ÉTABLISSEMENT DU TEMPORISATEUR

Pour l'utiliser, placez le sélecteur (tourner dans le sens horaire) à l'heure souhaitée pour couper. Le cadran est marqué en 3 tranches d'une minute vingt (Toute position entre les deux est une estimation du fait que le temps). Le cadran de la minuterie rotation automatique (sens anti-horaire) et coupera l'alimentation en gaz lorsque la molette atteint OFF (le temps est terminé).

**Important:** Lorsque vous utilisez la minuterie pour des périodes de moins de vingt minutes, vous devez d'abord régler le cadran à vingt minutes (pour activer), puis retour (sens anti-horaire) à la quantité désirée de temps. Cela permettra d'assurer le bon fonctionnement de la minuterie. Voir Fig. 22- 4.

### ÉCLAIRAGE MANUEL

**ATTENTION:** Attendez toujours cinq (5) minutes le gaz pour se dégager après que n'importe quelle tentative non réussie d'éclairage.

1. Suivez les étapes 1 à 4 (à gauche).
2. Passez un allumeur brûlant de butane de long-baril ou une allumette brûlante de long-tige dans la grille à cuire s'ouvrant au dessus du tube d'éclairage. (Fig. 22-2). Pour des backburners, tenez la flamme contre le surface du backburner.
3. Maintenez le match / flamme d'un briquet à la partie supérieure du tube d'éclairage pendant 5 secondes, ou, à côté de la veilleuse. Puis appuyer sur le bouton de contrôle approprié et en appuyant tourner dans le sens antihoraire à la position HI LIGHT. Retirez le briquet ou des allumettes quand le brûleur s'allume, puis relâchez le bouton de commande.
4. Si le brûleur ne se allume pas dans les cinq (5) secondes de tourner le bouton de commande, enfoncez immédiatement le bouton et tournez la valve à AU LOIN. ATTENDEZ CINQ (5) MINUTES avant de répéter les étapes 2 à 4 des instructions manuelles d'éclairage.

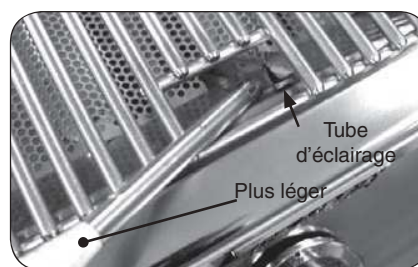

Fig. 22-2 - Éclairage manuel

### ARRÊT DU UNITÉ

Pour couper le unité, diminuez chaque bouton de commande de valve et tout en pressant tour il dans le sens des aiguilles d'une montre à la position de repos.

Fermez toujours la valve de la fourniture de gaz après chaque utilisation du unité.

Fig. 22-4

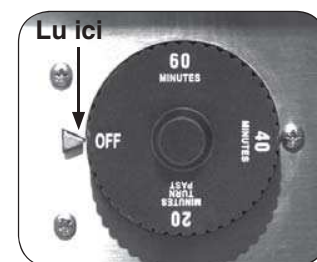

Bouton de temporisateur AU LOIN (temporisateur de 3 heures montré)

## LIGHTING (IGNITION) INSTRUCTIONS

Read all instructions before lighting, and follow these instructions each time you light the unit.

### ELECTRONIC LIGHTING

**Note:** This unit must be connected to 120VAC power for electronic lighting.

1. Open lid(s) or remove cover(s) from burner(s) to be lit.
2. Turn all gas control knob(s) to their **OFF** position(s).
3. Turn on the gas at its source.

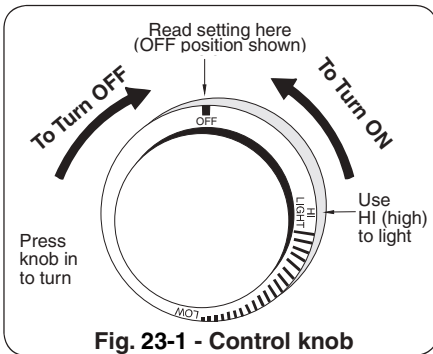

**Note:** DO NOT turn on more than one valve at a time for either electronic or manual lighting.

4. Set timer control knob to the desired cooking time.
5. Depress the desired control knob **for 5 seconds**, then, while pressing turn it counterclockwise to the **HI LIGHT** position. Once the burner lights, release the knob.

**CAUTION:** If a burner does not light within five (5) *seconds* of turning on the control knob, depress the knob and turn it to the **OFF** position. **WAIT FIVE (5) MINUTES** before repeating step 4. If you smell gas, follow the instructions on the cover of this manual. If the burners still do not light after several attempts, refer to the instructions for manual lighting.

6. Repeat step 5 for each additional burner to be lit.

### SETTING THE TIMER

To use, set the dial (turn clockwise) to the desired time to shut off. The dial is marked in 3 twenty minute increments (any position in between is an estimate of that set time). The timer dial will auto rotate (counter-clockwise) and will shut off the gas supply when the dial reaches OFF (i.e. the time is completed).

**Important:** When using the timer for periods of less than twenty minutes, you must first set the dial to twenty minutes (to activate), then return (counter-clockwise) to the desired amount of time. This will ensure proper timer operation. See Fig. 23-4.

### MANUAL LIGHTING

**CAUTION:** Always wait five (5) minutes for gas to clear after any unsuccessful lighting attempt.

1. Follow steps 1 through 4 (left).
2. Insert either a burning long-barrel butane lighter or a burning long-stem match through the cooking grid opening to the top of the lighting tube. (Fig. 23-2). For backburners, hold the flame against the surface of the backburner.
3. Hold the match / lighter flame at the top of the lighting tube **for 5 seconds**, or, next to the backburner. Then depress the appropriate control knob and while pressing turn it counterclockwise to the **HI LIGHT** position. Remove the lighter or match when the burner lights, and release the control knob.
4. If the burner does not light within five (5) seconds of turning the control knob, **immediately depress the knob and turn the valve to OFF**. **WAIT FIVE (5) MINUTES** before repeating steps 2 through 4 of the **MANUAL LIGHTING** instructions.

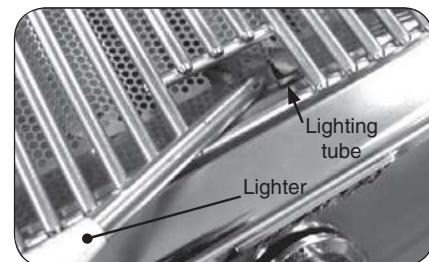

Fig. 23-2 - Manual lighting

### SHUTTING OFF THE UNIT

To shut off the unit, depress each valve control knob and while pressing turn it clockwise to the **OFF** position.

Always close the valve from the gas supply after each use of the unit.

Fig. 23-4



Timer knob in OFF position

## OPTIONAL DIGITAL THERMOMETER

Your grill comes with a digital thermometer for oven and meat probe temperature monitoring, and timed cooking. Pressing the power button will turn on the thermometer. The thermometer will automatically shut off after 5 minutes if no temperature change is detected.

The thermometer is located on the control panel between the control knobs.

Plug in the meat probe on the right side of the control panel as shown in Fig. 24-1.

**FOR BEST PERFORMANCE, GENTLY PRESS THE BUTTONS.** When turned on, accurate temperature readings will begin after the thermometer has initialized. When turned off, allow 5 seconds prior to turning back on.

Read the following sections completely regarding thermometer operation. Refer to Fig. 24-2 for thermometer orientation and button locations.

### DEFAULT SCREEN

**Press the power button to turn the thermometer ON.** The default screen will be displayed. Temperatures for the oven and meat probe will be shown (Fig. 24-3). See below for options under the default screen.

### Setting a Location Temperature

1. Press the up/down arrow to switch to the desired location (oven or meat probe). Location will be highlighted when selected. Press **SET**.
2. The selected location's temperature screen will be displayed. Use the arrows to set the desired temp. The actual temp. will also be shown. (See Fig. 24-4)

**Note: PRESSING the arrows will adjust the desired temp. by increments of one degree. HOLDING them down (for several seconds) will adjust the temp. rapidly.**

3. Press **SET** to return to the default screen. Repeat as necessary for other location.

The display will flash red and the alarm will sound (if set to do so) when the oven / meat probe reaches its set temperature. The alarm is silenced by pressing any button on the thermometer.

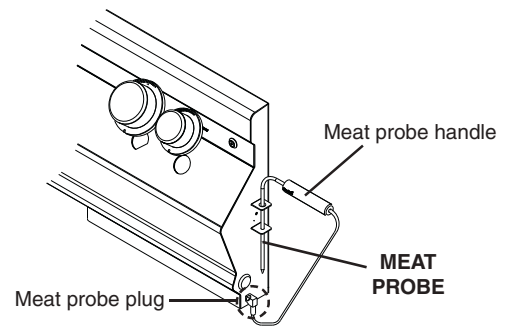

Fig. 24-1 Meat probe detail

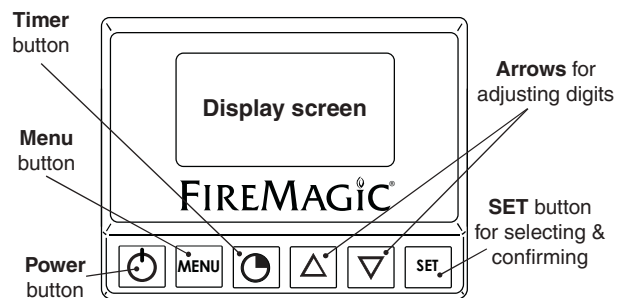

Fig. 24-2 Orientation

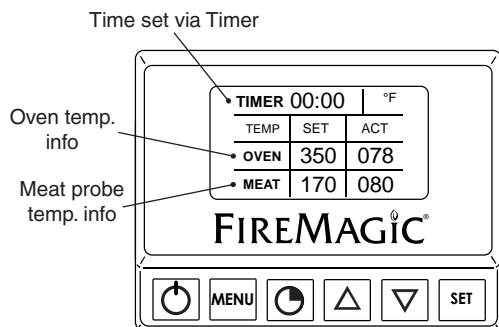

Fig. 24-3 Default screen detail

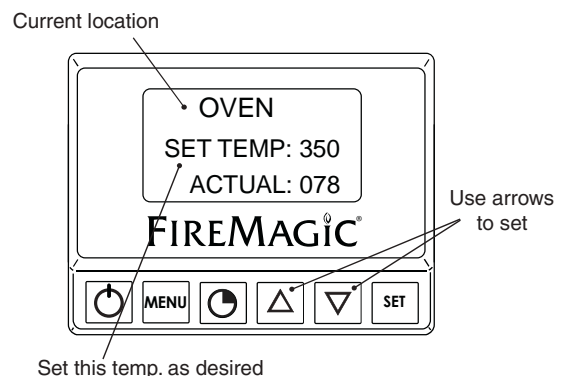

Fig. 24-4 Location temp. screen (oven shown)

## OPTIONAL DIGITAL THERMOMETER (cont.)

### Setting the Timer

1. Press the timer button. Use the arrows to set the desired amount of time (see Fig. 25-1.)
2. Press **SET** to return to the default screen.

The time remaining will be shown on the default screen. Once the time reaches zero; the display will flash red and the alarm will sound. The alarm is silenced by pressing any button on the thermometer.

### MENU SCREEN

Press the power button to turn the thermometer **ON**. The default screen will be displayed. Press the **MENU** button to display its screen. Press the up/down arrow to scroll through the options. (See Fig. 25-2.) See below for options under the menu screen.

**Note:** The menu screen will return to the default screen after approximately 30 seconds of no activity. Press the **MENU** button to manually return to the default screen.

### Changing temperature units (°C/°F)

1. Under the menu screen select SETUP. Press **SET**.
2. Press the up/down arrow to select SETUP FC. Press **SET**.
3. Press the up/down arrow to select the desired temperature unit (°C/°F).
4. Press **SET** to return to the menu screen.

### Grill Guide and Meat Probe

The grill guide displays recommended ready temperatures for various meats.

1. Under the menu screen select GRILL GUIDE. Press **SET**.
2. Press the up/down arrow to view the desired meat.
3. Note the temp. and press **SET**. This will take you to the meat probe temperature screen.
4. Use the arrows to set the noted temp.
5. Press **SET** to return to the default screen.

Putting the meat probe into the cooking meat will give an actual temp. reading. The display will flash red and the alarm will sound (if set to do so) when the actual temp. reaches the set temp. The alarm is silenced by pressing any button on the thermometer.

**Note:** Do not leave the meat probe in the meat for a prolonged period of time, or with the hood closed.

**Note:** The meat probe is calibrated specifically for use at temperatures between 130°F and 180°F.

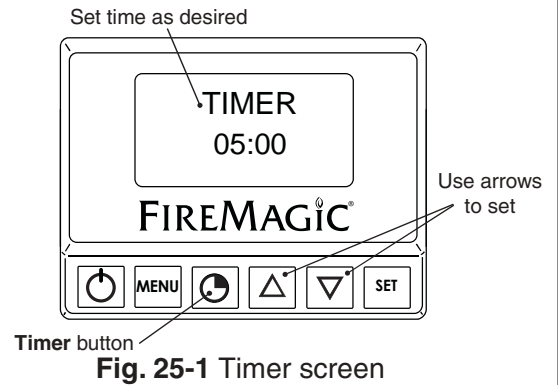

Fig. 25-1 Timer screen

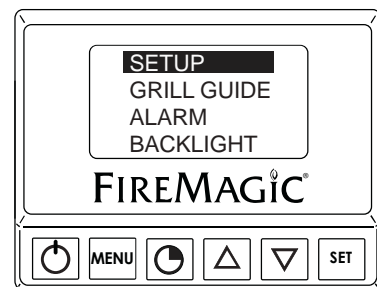

Fig. 25-2 Menu screen

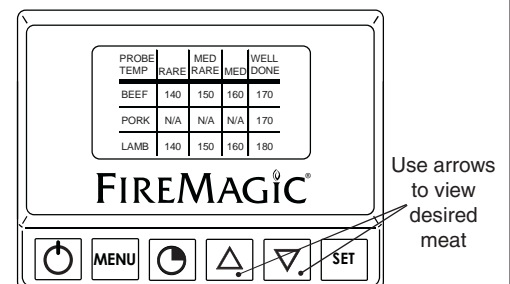

Fig. 25-3 Grill Guide screen



Fig. 25-4 Meat probe

## OPTIONAL DIGITAL THERMOMETER (cont.)

### Setting the Alarm

The alarm can be individually set (ON or OFF) for the meat probe and oven temp. The default setting has the alarm OFF for the meat probe and oven temp. The alarm always alerts for the TIMER.

1. Under the menu screen select ALARM. Press **SET**.
2. Use the up/down arrow to select the desired alarm, and press the power button to turn the alarm ON/OFF.
3. Press **SET** to return to the menu screen.

### Setting the Thermometer Backlight

The default color for the thermometer backlight is blue. The color may be changed as desired by turning the three base colors ON/OFF. Various combinations will result in different colors.

1. Under the menu screen select BACKLIGHT. Press **SET**.
2. Use the up/down arrow to select the desired color, and press the power button to turn the color ON/OFF.
3. Press **SET** to return to the menu screen. The new color will be displayed.

**Note:** Turning all colors OFF will result in no backlight.

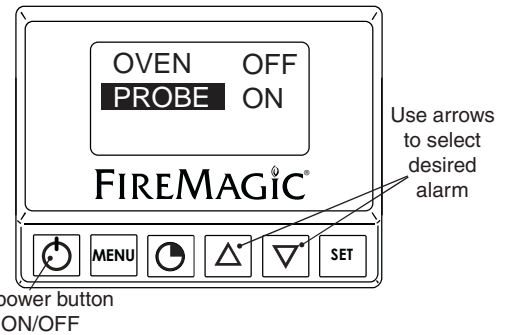

**Fig. 26-1** Alarm screen

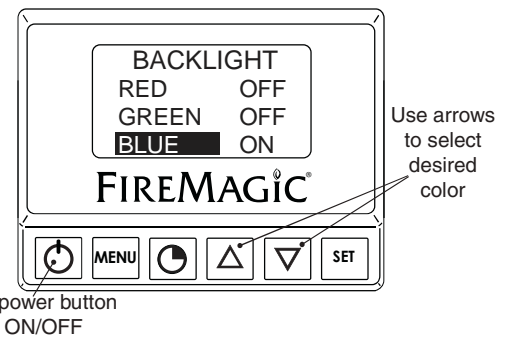

**Fig. 26-2** Backlight screen



## OPTIONAL ROTISSERIE

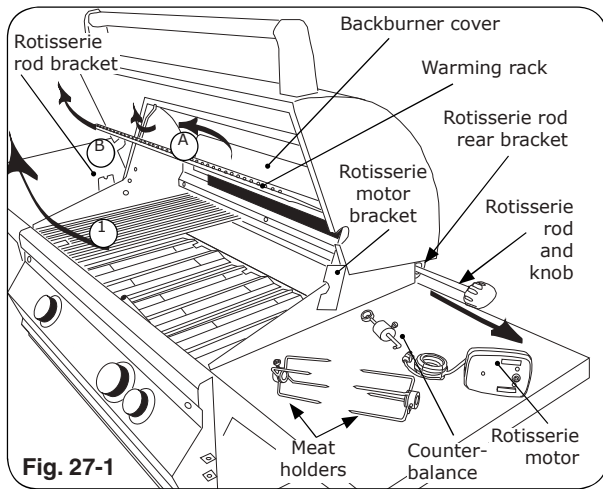

Fig. 27-1

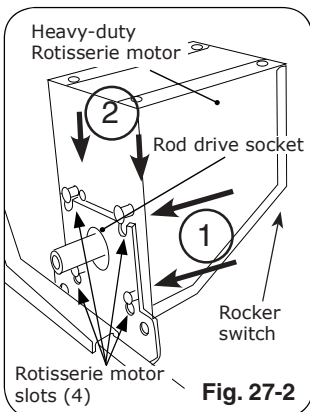

Fig. 27-2

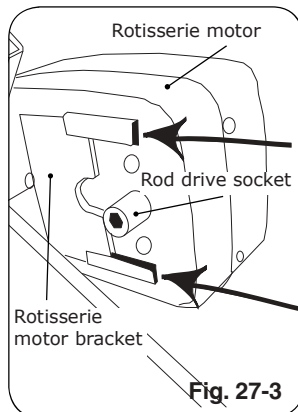

Fig. 27-3

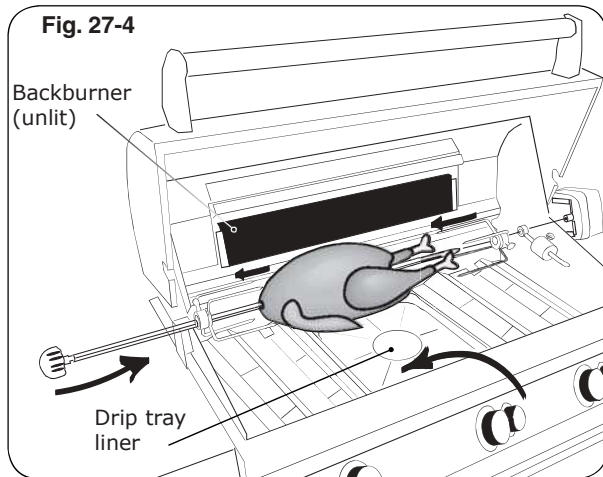

Fig. 27-4

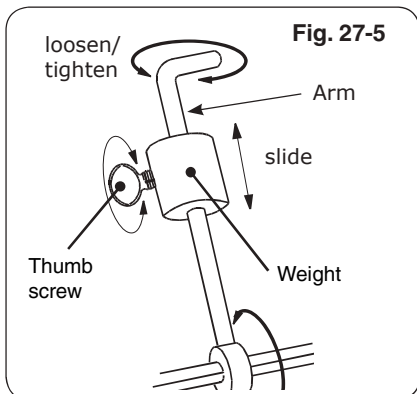

Fig. 27-5

**CAUTION: WHEN USING THE BACKBURNER; KEEP THE OVEN LID CLOSED TO PREVENT HEAT LOSS, PROVIDE PROPER CONVECTION, AND PROVIDE PROPER VENTING. THIS WILL ENSURE EVEN COOKING TEMPERATURES.**

**DO NOT KEEP YOUR OVEN LID OPEN DURING ROTISSING, AS THIS MAY CAUSE PERSONAL INJURY, OR IN SOME CASES, IN WINDY CONDITIONS, DAMAGE TO THE GRILL.**

**DO NOT USE THE ROTISSERIE MOTOR IN THE RAIN. DO NOT LEAVE THE MOTOR ON THE GRILL WHEN NOT IN USE.**

1. Remove warming rack, backburner cover, and cooking grids. Leave the flavor grids on if possible.
2. Slide rotisserie motor fully onto motor bracket (right side, Fig. 27-1, Fig. 27-2 and Fig. 27-3).
3. Remove rotisserie rod from rear bracket (Fig. 27-1) and attach knob if necessary.
4. Slide the left meat holder onto the rod (and tighten), the meat onto the rod and into the holder, followed by the right meat holder onto the rod and into the meat as shown in Fig. 27-4. Tighten the right meat holder. Be sure the meat is centered and balanced as well as possible.
5. Hold both ends of the rod so it settles freely (do not grip tightly). Allow the rod to rotate until the heavy side of the meat rests downward.
6. The counterbalance may then be attached to even weight distribution. Slide counterbalance onto rod next to the meat holder. Loosen the arm and point it upward opposite the heavy side of the meat. Tighten the arm.
7. Slide the counterbalance weight up or down the arm until the rod rotates most evenly then tighten thumb screw (Fig. 27-5 and Fig. 27-6).
8. Insert the pointed end of the rod into the motor drive socket and the groove next to the knob into the left support bracket.
9. To keep drippings off the burners and simplify cleanup, place Fire Magic® drip tray liners under the meat, if desired (Fig. 27-4).
10. Plug-in the rotisserie motor and press the rocker switch to start.
11. Light backburner per lighting instructions in this manual (or on drip tray handle) and close oven lid.

**Important:** Turn the backburner to low or off when stopping the rotisserie to prevent overcooking.

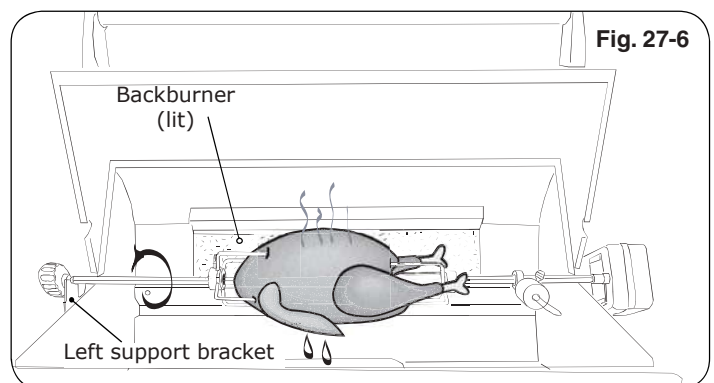

Fig. 27-6

## OPTIONAL INFRARED BURNER OPERATION

The infrared (IR) searing burner (optional) cooks with a powerful radiant heat.

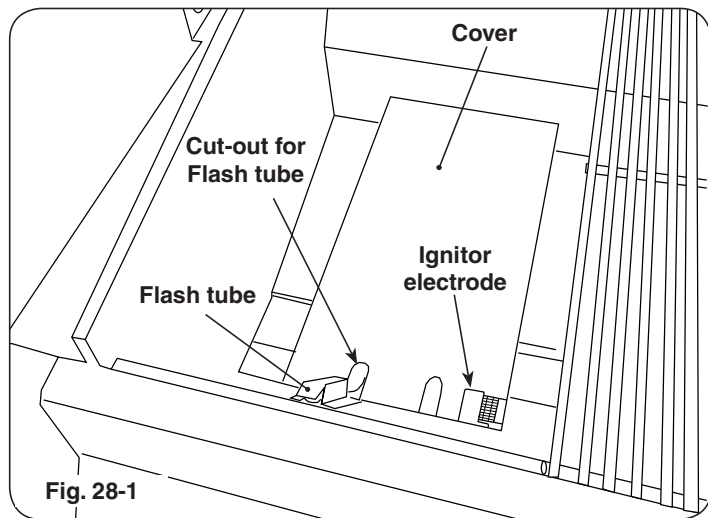

Fig. 28-1

Light the infrared burner following the LIGHTING INSTRUCTIONS in this manual or printed on the drip tray. Follow these guidelines when operating the Infrared burner:

- **DO NOT** place food on the cooking grid until the IR burner glows orange (Fig. 28-3). Drippings are heated and evaporate instead of sticking to and impairing burner function.
- For cleaning purposes; always leave your burner on (after cooking) for an additional 5 minutes, to allow for a burnoff period. This is important to keep your burner clean and operating properly. **As the burner is self cleaning (at full temperature); avoid the use of cleaners or abrasives.**
- When not in use, **always** cover the infrared burner with the stainless-steel cover. This protects the burner from drippings (from other cooking), airborne particles, and foreign objects (Fig. 28-2).
- Do not strike or scratch the burner ceramic as it may chip, crack, or break (Fig. 28-2).

**Note:** Digital thermometer (if equipped) does not give accurate readings for infrared burners.

**Important:** When grilling with the infrared burner, always place a cooking grid above it. The cooking grid must be removed for rotisserie cooking.

**CAUTION:** DO NOT operate your IR burner with the oven hood closed.

**CAUTION:** Never attempt to operate the IR burner with the protective cover in place.

### WARNING

Only handle the infrared burner cover when the unit is cold or with a well-insulated long-handled tool or heat resistant gloves.

#### SIDE VIEW (with cover on)

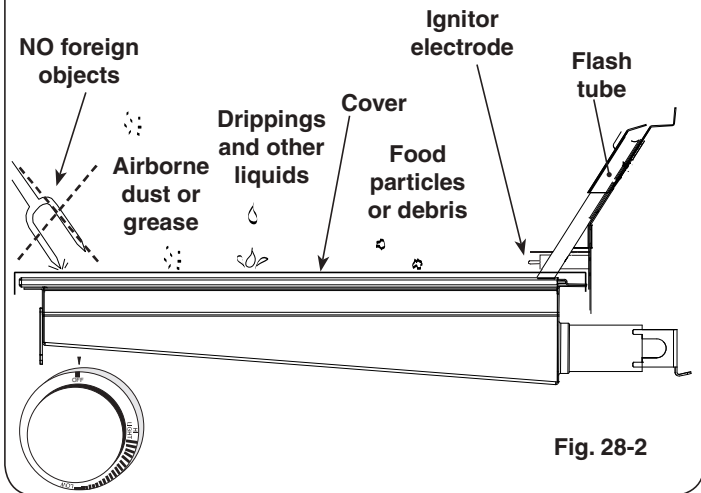

Fig. 28-2

Burner ceramic must be protected with cover when burner is not in use.

#### SIDE VIEW (burner on HI LIGHT and glowing orange)

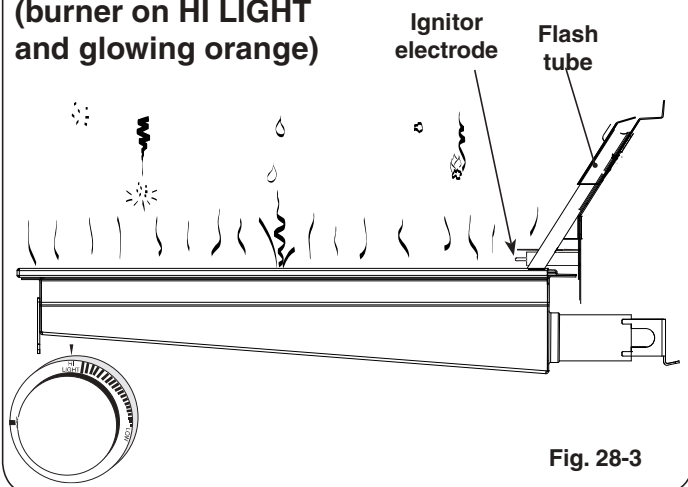

Fig. 28-3

Drips and particles evaporate before hitting infrared burner when cooking at the maximum setting.

**Note:** Flavor grids are not to be used with infrared burners.

To ensure proper operation, all infrared burners (back and main) must be operated on the HI setting for a minimum of 10 minutes. Thereafter, the flame may be lowered as desired.

**CAUTION:** Always monitor the infrared burner flame when operated on low, as it may blow out in high-wind conditions.

## ACCESSORIES

### GRILL BRUSH (optional)

Purchase a Fire Magic® stainless-steel grill brush (sold separately) to keep your grill cleaner. It comes with scraper for large particles and a replaceable head with brass bristles for overall cleaning.



Fig. 29-1

Grill brush with replacement head

### WARMING RACK (if equipped)

The warming rack (Fig. 29-2) is packed separately.

To install the warming rack, lift the front of the rack up slightly and insert the rack hangers into the two holes in the back of the inner oven hood. Then lower the front of the rack into a level position to lock the rack in place.

To remove the warming rack, lift up on the front of the rack until the rack hangers pull free from their supporting holes.

**Note:** Removing the warming rack before using the rotisserie will leave more clearance for the meat being cooked. (if applicable)

### THE COOKING GRID LIFTER

Hold the grid lifter by gripping the center section with the prongs pointing down (use an oven mitt or heavy glove if the grill is hot). Insert the notched end of the grid lifter into the cooking grid, in front of the midway point (front to back; Fig. 29-3), and central (left to right; Fig. 29-4). Twist the grill lifter (clockwise or counterclockwise) so the handle is parallel to the grill rods. This “seats” the spiked end of the grid lifter between two rods, enabling you to safely lift out the grid. Lift slowly and adjust the grid lifter, if necessary, for balance.

### THE DRIP TRAY

The drip collection system allows you to brush or scrape excess dried residue from the grilling area directly into the drip tray (see the DRIP TRAY section for more information).

### THE FLAVOR GRID(S)

Place each flavor grid directly over a burner. The solid areas of the grid should rest over the tabs found on the burner. See Fig. 29-5. **The slightly larger grids are designed to be placed over the outside burners, and the slightly smaller grid(s) are designed to be placed over the interior burner(s).**

**Note:** This allows heat from the burners to be evenly distributed throughout the cooking area. The flavor grids heat and cool quickly, making the grill very responsive to changes in heat from the burners.

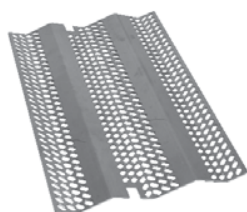

Fig. 29-5  
Flavor grid



Fig. 29-2 Warming rack in place inside oven



Fig. 29-3



Fig. 29-4

Placement of the grid lifter in cooking grid

## FIRE MAGIC® DRIP TRAY

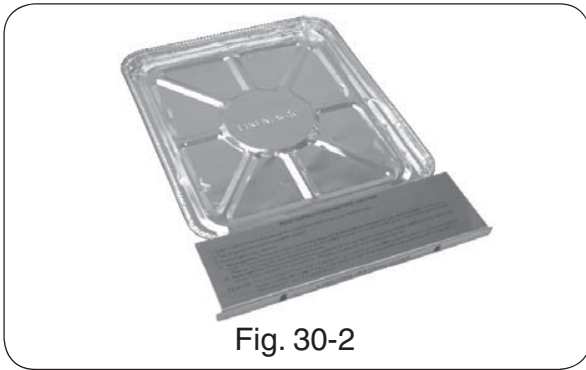

Fig. 30-2

Pull out the drip tray and place liner

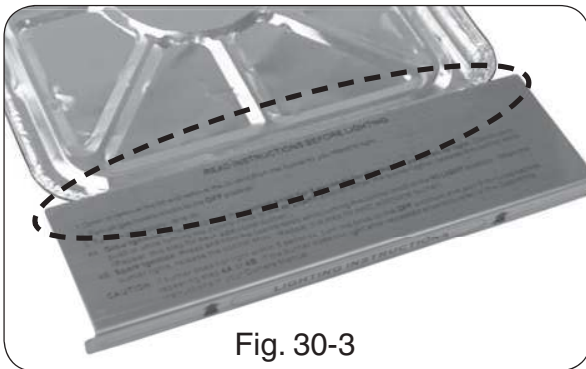

Fig. 30-3

Be sure liner fits under lighting instruction plate

The drip collector allows you to brush or scrape residue from the grill's inner liner into the drip tray. Following the manufacturer's instructions and regular cleaning of the grill's interior with oven cleaner, will help to prevent grease fires.



Fig. 30-1

Your grill includes a pack of four (4) Fire Magic® drip tray liners (Fig. 30-1). For your convenience in cleanup, place a liner into the drip tray before grilling.

To fit a liner into the drip tray, pull out the tray and set it on a flat, level surface. Place the liner in the drip tray as shown in Fig. 30-2 and carefully insert the tray back under the control panel.

**Note:** Be sure that the liner is properly placed into the drip tray. The front of the liner must fit under the drip tray's lighting instruction plate (see 30-3 detail).

After each use, wait for the grill to cool and carefully pull out the drip tray to check it. When a liner is nearing full, carefully lift it out of the drip tray, lifting with both hands to keep the tray level until it is safely discarded. Then insert a new drip tray liner.

Order more drip tray liners through your local Fire Magic® dealer.

**Note:** The foil tray liner is also useful for setting on burners to cover them and catch drippings directly during rotisserie only cooking.

**Note:** There are easy to follow lighting instructions etched onto the top of the drip tray handle.



## CARE & CLEANING

APPLIANCE MUST BE COMPLETELY COOL WHEN CLEANING. DO NOT SPRAY ANY CLEANER OR LIQUIDS ON THE APPLIANCE WHEN HOT.

The appliance *must* be cleaned as often as once a month (depending on use) to prevent grease build-up and other food deposits.

### INTERIOR

THE **BURNER PORTS AND CARRY-OVER PORTS/SLOTS** MUST BE KEPT CLEAN TO ENSURE PROPER IGNITION AND OPERATION.

Remove the burner (see orifice changing instructions) and clean the ports and slots as required. (For Fire Magic grills use Maintenance Kit part #MK-1.) Also inspect and clean the burner inlet for insects and nests. A clogged burner can lead to a fire in the bottom of the appliance.

The inside of the appliance may be cleaned periodically with oven cleaner if desired. Follow the oven cleaner instructions for proper use.

Be careful not to get oven cleaner on the outside surface of the appliance as it can permanently damage the finish.

### EXTERIOR

Stainless steel surfaces when exposed to temperatures produced by the grilling process will change color. The stainless steel will change color from silver to brown and blue. This can be removed by using stainless steel cleaner.

Clean your appliance by first using grill cleaner to remove grease and dirt. Always wipe with the grain (See Fig. 31-1). Next, use stainless steel cleaner to restore the stainless steel color (Note: not for mirror finish). Finish by wiping your appliance down using polish wipes. **To clean any mirror finish (if applicable), use a quality brand glass cleaner only, not any of the cleaners mentioned above.**

If your appliance is installed in a seaside (salt air) or poolside (chlorine) location, it will be more susceptible to corrosion and must be maintained/cleaned more frequently. Do not store chemicals (such as chlorine or fertilizer) near your stainless steel appliance.

Due to the nature of stainless steel, surface iron oxide deposits may appear. Do not be alarmed – these deposits are removable with stainless steel cleaner through prompt and periodic maintenance. If not attended to promptly, permanent pitting may occur.

By following these recommendations, you will enjoy the beauty and convenience of your appliance for many years to come.



Fig. 31-1 - Wipe with grain

### PROTECTING YOUR APPLIANCE FROM THE WEATHER

An optional cover will protect your appliance when not in use. (Allow to cool before covering.)

Please specify the model number and serial number of your appliance when ordering a cover.

### IMPORTANT

**IN THE EVENT OF A GREASE FIRE, IMMEDIATELY SHUT OFF THE MAIN GAS VALVE TO THE UNIT. KEEP THE LID OPEN AND ALLOW THE FIRE TO EXTINGUISH ITSELF. A THOROUGH INSPECTION BY A TRAINED SERVICE TECHNICIAN SHOULD BE CONDUCTED BEFORE FUTURE USE OF YOUR UNIT. THE SERVICE TECHNICIAN WILL CHECK THE SYSTEM FOR GAS LEAKS AND WILL CHECK ALL ELECTRICAL WIRING FOR DAMAGE. ALL GAS LEAKS AND WIRING MUST BE REPAIRED PRIOR TO FUTURE USE.**

## REPLACING HALOGEN BULBS

Your grill is engineered with the conveniences of electrical power for illuminating and igniting the grill.

To replace any oven light, follow the instructions below.

**Important:** ONLY REPLACE WITH 12V / 10 WATT HALOGEN BULB(S).

### WARNING

To protect from potentially sharp sheet metal and glass, wear gloves and safety glasses during this procedure.

1. Turn all burner control knobs to the **OFF** position and shut off the gas supply to the grill at the source (tank valve for propane units or gas line shut-off valve for natural gas units.)
2. Disconnect supply of external electrical power to the grill.

**CAUTION:** Wait for the grill, oven, lens, light bulb, and fixture to cool before proceeding to the next step.

3. Open the oven lid.

**Important:** Place one hand directly below the glass lens and prepare to catch it when it is detached.

4. Carefully insert a standard flat head screwdriver or thin plastic spatula between the glass lens and the stainless steel on which the light is mounted and gently pry the glass lens out in such a way that the stainless steel is not scratched (twisting the screwdriver handle, for instance). Catch the lens and set it safely aside.

**Note:** You may wish to take this opportunity to clean the lens with a standard household window cleaner and then dry it completely.

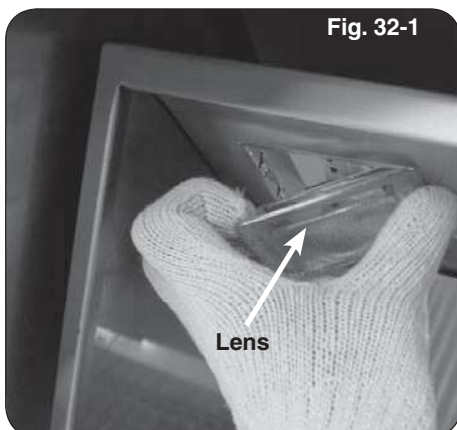

5. Wearing a pair of gloves, reach into the fixture, gently grab the bulb, and pull it straight out of the fixture so that the two pins at the base of the bulb come all the way out.

**Important:** Bulb is halogen. DO NOT TOUCH with bare hands. Oils from hands drastically reduce bulb life.

**Note:** It may be helpful to rock the bulb gently backward and forward while pulling it out.

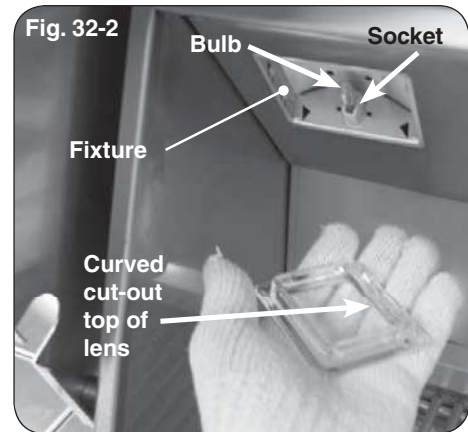

6. Inspect the old bulb for broken glass or filament.

**Note:** It may be beneficial to test a suspect bulb in one of the other light fixtures known to be working and turn the power back on to be certain the bulb is actually not working.

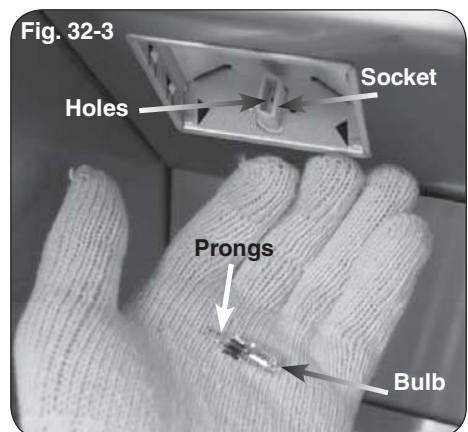

7. Insert the new **12V / 10 watt** halogen bulb into the socket so that both pins slide all the way into the two holes in the bottom of the socket.

8. Place the lens back into the fixture opening with the curved cut-out on the bottom and snap it back into place.



## CONVERT GAS TYPE / CHECK BURNER ORIFICES

**CAUTION:** Make sure the grill is at a safe temperature and isolated from gas and electrical supplies before beginning.

For your safety, exercise caution, and make sure you have adequate hand protection, such as gloves, when handling metal parts.

### CONVERT LABEL

This grill comes from the factory configured for one type of gas as marked on the label behind the control panel.

**When the grill is converted, the label for the new gas (included at original shipping) MUST be applied over the old label mentioned above.**

### CONVERT REGULATOR

The gas regulator, located behind the control panel, must be set for the type of gas used to fuel the grill. To check the regulator setting, remove the cap in the center of the regulator (Fig. 33-1, A). Holding the cap vertical (see Fig. 33-1, B), the letters at the bottom of the plastic stalk indicate the gas type for which the regulator is currently configured.

If the text on the bottom of the regulator stalk does not match the gas type connected to the grill, remove the stalk from the cap, invert, and replace into center of cap. Replace cap on the regulator, screwing down until snug.

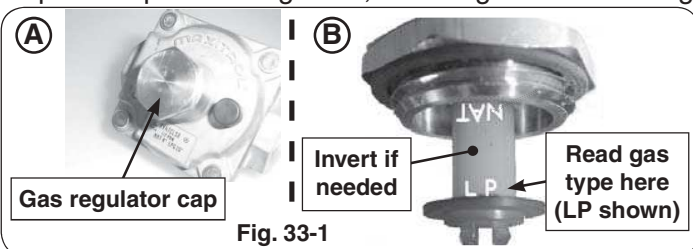

### CONVERT GAS ORIFICES

When converting the grill to a different gas type, each burner's orifice must be replaced with the corresponding orifice for the new gas.

See MODEL SPECIFICATIONS TABLE, Table 1 at the beginning of this document to determine the proper orifice sizes for each burner.

**See the following sections for details on orifice conversion.**

**Important:** It is critical to the operation of each burner that its orifice be fully inserted into the center of its orifice opening.

#### **WARNING**

**HAZARDOUS OVERHEATING WILL OCCUR IF A NATURAL-GAS ORIFICE IS USED WITH PROPANE GAS.**

### CONNECT TO NEW GAS SUPPLY

Plumb the unit as appropriate for the new gas supply. (Additional components may be needed for your specific setup.) **Be sure to leak test at all connections.**

### CONVERT/CHECK MAIN BURNER ORIFICES

1. Remove the cooking grid and flavor grid from above the burner you are working on and set them aside.
2. Remove the cotter pin from the left or right rear burner anchoring peg by pulling it straight out of the cotter pin hole using fingers or needle-nose pliers (Fig. 33-2).
3. Lift the back end of the burner out of the anchor peg holes, then move the burner toward the back of the grill to clear the gas inlet and set it aside.

**CAUTION: THE BURNER IS HEAVY.**

4. Use a  $\frac{3}{8}$ " hex nut driver to remove the exposed orifice (Fig. 33-3). Check orifice. If needed, replace it with the correct orifice for the new gas.
5. Replace the burner by first sliding the open cylindrical end of the burner around the orifice, enveloping it and centering on it, then lower the back end anchor pegs into the anchor peg holes.

**Note:** It is critical to the continued safe functioning of the burner that the orifice is centered and completely inside the burner gas inlet.

6. Reinsert the cotter pin into the right rear burner anchor peg using fingers or needle-nose pliers.
7. Replace the flavor grid and then the cooking grid so that the cut-out section is in front.
8. Repeat these steps for each main burner.

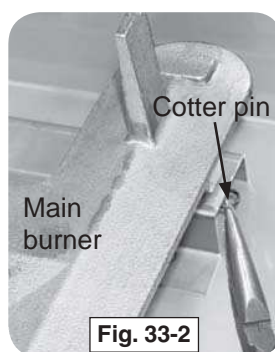

### CONVERT/CHECK BACKBURNER ORIFICE (IF EQUIPPED)

1. Remove the warming rack if installed and set it aside.
2. Remove the backburner cover.
3. Unscrew all backburner access plate screws using a Phillips-head screwdriver and set them aside.

## CONVERT GAS TYPE / CHECK BURNER ORIFICES (cont.)

4. Remove the access plate by pulling the bottom toward the front of the grill and rotating it upward and outward until the two top tabs attached to back wall of the oven can be removed from the slots in the top of the plate.

5. Remove the backburner assembly retaining screw on the lower left of the backburner using a Phillips-head screwdriver and set it aside.

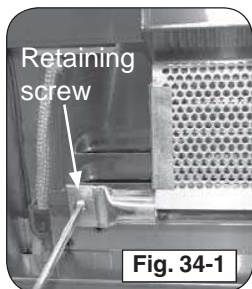

6. Pull out the wire from the ignitor electrode (Fig. 34-2), then carefully remove the backburner by slightly sliding it to the left.

**CAUTION:** Be careful not to damage the wires connected to the backburner assembly.

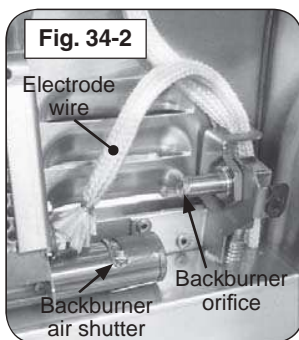

7. Use a  $\frac{3}{8}$ " hex nut driver to remove the exposed orifice. Check orifice. If needed, replace it with the correct orifice for the new gas.
8. Replace the backburner assembly and reinsert the retaining screw. Center the backburner assembly so that the backburner plate will fit over it. Tighten the retaining screw using a Phillips-head screwdriver.
9. Replace the access plate by first inserting the tabs above into the slots in the top of the plate and then rotating the bottom downward and inward.
10. Replace all the access plate screws using a Phillips-head screwdriver.

### CONVERT/CHECK INFRARED BURNER ORIFICE (IF EQUIPPED)

1. Remove the cooking grid from above the burner.
2. Unscrew both lighting tube hex head screws with a  $\frac{3}{8}$ " hex nut driver.
3. Remove the infrared burner by lifting the back of the burner up so that both tabs are freed from their slots, then lift the burner toward the back of the fire box and upward. Set the burner aside.
4. Use a  $\frac{3}{8}$ " hex nut driver to remove the exposed orifice. Check orifice. If needed, replace it with the correct orifice for the new gas.
5. Replace the infrared burner by first sliding it over the orifice, then lowering the two tabs under the back of the burner into the slots in the back burner rest.
6. Reattach the lighting tube and replace the grid so that the cut-out section is in front.

## BURNER AIR SHUTTER ADJUSTMENT

### AIR SHUTTER ADJUSTMENT

**Important:** Air shutters are preset at the factory based on the gas the grill is built to burn. However, altitude or other local conditions may require air shutter adjustment for proper combustion.

### MAIN BURNER

Flames from a properly adjusted main burner with no wind or breeze present will appear fairly steady, consistent, and mostly blue. If the tip of a flame were to turn orange, it should only do so briefly and then become blue again. The flames will appear to burn while touching the burner ports (see Figure 35-1).

If the flames have orange in them and appear to undulate slowly from side to side, or if some of them appear to lift off the burner instead of touching it, then adjust the air shutter, as instructed below.

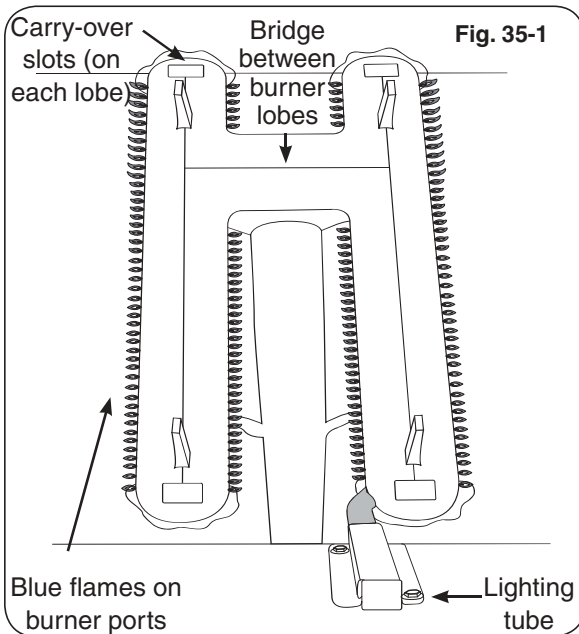

**CAUTION:** Turn all burner control knobs to the **OFF** position and turn off the gas supply at the source before removing or adjusting a burner.

### **WARNING**

Wait for the burner to be cool or use heavily insulated heat-resistant gloves when handling the burner.

1. Follow the safety precautions and steps for main burner removal in the **CHANGING THE MAIN BURNER ORIFICES** section (steps 1-4).

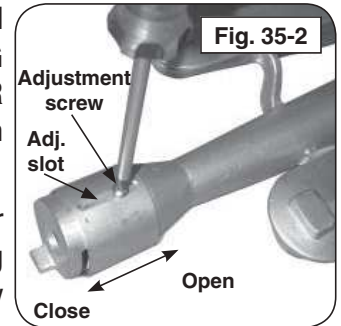

2. Adjust the air shutter opening by loosening the adjustment screw with a screwdriver, then sliding the air shutter backward or forward to open or close the air shutter opening (see Fig. 35-2).

Shutter Setting	Flame Condition
Open too far	Flames shorten and lift off the burner
Ideal setting	Blue flames just touching burner
Closed too far	"Lazy" flames with orange in them

Too large an air shutter opening will allow too much air into the burner, which will cause the flames first to shorten and then to appear to lift up off the ports. For the bottom of the flames to move closer to the ports, close the air shutter more.

If the air shutter opening is too small or closed, the flames will present consistently orange tips and become "lazy," slowly undulating back and forth.

For propane gas, ideal settings tend to be just slightly open. For natural gas, which generally requires less primary air than propane, the main burner air shutter may be nearly closed.

3. Adjust the air shutter opening and then replace the burner (steps 6-8 in the **CHANGING THE MAIN BURNER ORIFICES** section).
4. Follow the lighting instructions in this manual to light the burner.
5. Repeat steps 1-4 until the flames appear to touch the burner ports, burning fairly steadily and mostly blue (see Fig. 35-1).

## BURNER AIR SHUTTER ADJUSTMENT (Cont.)

### BACKBURNER (IF EQUIPPED)

The air shutter is set at the factory. However, altitude or other local conditions may require air shutter adjustment for proper combustion.

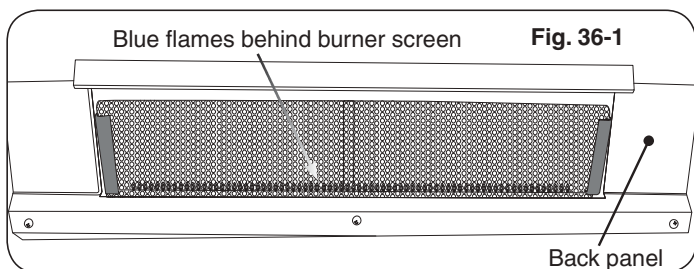

Flames from a properly adjusted backburner will appear as a horizontal line of even blue flames along the bottom of and behind the backburner grating. The grating itself will glow red after it heats up.

**Note:** It is normal for the backburner to smoke when it is first used. Burning the backburner on **HI LIGHT** for approximately 15 minutes will eliminate the smoking.

If, instead of being blue and even, the backburner flames appear to have orange in them and waver slowly left and right, or if the flames appear to lift off the burner, adjust the backburner air shutter by following the steps below.

The backburner air shutter adjustment is located behind the right side of the access panel in the back of the oven, above the cooking grid.

**Note:** It is only necessary to remove the backburner back panel, not the backburner, when adjusting the backburner air shutter.

1. Follow the safety precautions and steps for backburner back panel removal (steps 1-4) in the CHANGING THE BACKBURNER ORIFICE section.

**CAUTION:** The backburner air shutter can be safely adjusted with the backburner lit if it is adjusted using a long-handled screwdriver or well-insulated fire and heat-resistant gloves.

2. Adjust the air-shutter opening by loosening the adjustment screw with a screwdriver, then sliding the air shutter backward or forward to open or close the air shutter opening (see Fig 36-2). Watch the backburner flames while adjusting the air shutter.



Too large an air shutter opening will allow too much air into the burner, which will cause the flames first to shorten and then to appear to lift up off the ports. For the bottom of the flames to move closer to the ports, close the air shutter more.

If the air shutter opening is too small or closed, the flames will present consistently orange tips and become "lazy," slowly wavering left and right.

3. Continue adjustment until the flames appear to touch the burner ports, burning fairly steadily, consistently, and mostly blue (see Fig. 36-1), then retighten the backburner air shutter adjustment screw.
4. Replace the burner access plate (step 8 in the CHANGING THE BACKBURNER ORIFICE section).

## CONTROL PANEL REMOVAL

### To remove the control panel:

1. Turn the control knobs to the OFF position and turn off the gas supply to the unit.
2. Remove the drip tray.
3. Turn off the light switch and disconnect the power supply from the power source.
4. Pull the control knobs from the stems and set aside.
5. Using a Phillips screwdriver, unscrew and remove the control panel fastener screws and washers (located on the left and right front face of the control panel). Retain the screws for later re-installation.
6. Carefully open the control panel by lifting and pulling the control panel from the frame, allowing it to rest on the internal chain(s).

**Important:** When opening, take caution to not damage any wiring.

7. If wire disconnections are required, reference the wire diagram in the MODEL SPECIFICATIONS section in this instruction manual or the wire diagram label affixed to the inside of the control panel.

**Note:** Secure any disconnected wires (coming from the inside of the unit) to prevent them from falling in.

**Note:** Whenever reconnecting any wires, apply a small amount of dielectric grease to the male connector, then make the connection.

**Important:** During reinstallation; prior to opening the gas shutoff valve, be sure the control knobs are in the OFF position.

---

**NOTES PAGE**

---

Please use this page to record any information about your unit that you may want to have at hand.



## TROUBLESHOOTING

If you have trouble with the unit, please use this list to identify the problem. By trying one or more of the solutions to the possible cause, you should be able to solve the problem. If this list does not cover your present problem, or if you have other technical difficulties with the unit, please contact your local dealer.

PROBLEM	POSSIBLE CAUSE	CORRECTION
<b>Ignition system failure</b>	<ol style="list-style-type: none"> <li>1. Power supply failure</li> <li>2. Improper air shutter adjustment</li> <li>3. Ignition wire disconnected</li> <li>4. Low gas pressure</li> <li>5. Front carry-over port</li> <li>6. Ignitor switch malfunction on valve</li> <li>7. Ignitor malfunction</li> </ol>	<ol style="list-style-type: none"> <li>1a. System reset: Disconnect (wait 10 minutes minimum) and reconnect power to unit. With lights <b>OFF</b>, test ignition.</li> <li>1b. Replace power supply.</li> <li>2. Adjust air shutters.</li> <li>3. Reconnect wires into wire harness.</li> <li>4. Have the gas co. check supply pressure.</li> <li>5. Clean burner ports.</li> <li>6. Contact dealer for replacement.</li> <li>7. Contact dealer for replacement.</li> </ol>
<b>Insufficient heat / low flame</b>	<ol style="list-style-type: none"> <li>1. Improper air-shutter adjustment</li> <li>2. Using propane orifice for natural gas</li> <li>3. Low gas pressure/flame (propane)</li> <li>4. Low gas pressure/flame (natural)</li> <li>5. L.P. regulator hose cracked due to age</li> </ol>	<ol style="list-style-type: none"> <li>1. Adjust air shutters.</li> <li>2. Check/change orifices.</li> <li>3. Shut off all valves, including propane tank, and follow lighting instructions exactly. (See important note* below.)</li> <li>4. Have the gas co. check pressure at unit.</li> <li>5. Replace L.P. regulator hose.</li> </ol>
<b>Uneven heating</b>	<ol style="list-style-type: none"> <li>1. Burner ports partially blocked by debris</li> <li>2. Small spiders or insects in burner</li> <li>3. Improper air shutter adjustment</li> </ol>	<ol style="list-style-type: none"> <li>1. Remove burners and clean out ports.</li> <li>2. Inspect burners and orifices for spider webs or other debris that may block flow.</li> <li>3. Adjust air shutter.</li> </ol>
<b>Thermometer not operating</b>	<ol style="list-style-type: none"> <li>1. Power supply failure</li> <li>2. Thermometer failure</li> </ol>	<ol style="list-style-type: none"> <li>1. See 1a of <b>Ignition system failure</b> section above and/or replace power supply.</li> <li>2. Check and/or replace thermometer.</li> </ol>
<b>Rotisserie noisy</b>	<ol style="list-style-type: none"> <li>1. Rotisserie out of balance</li> </ol>	<ol style="list-style-type: none"> <li>1. Adjust rotisserie counterbalance.</li> </ol>
<b>Burner goes out on LOW</b>	<ol style="list-style-type: none"> <li>1. Valve "Low" setting needs adjustment</li> </ol>	<ol style="list-style-type: none"> <li>1. Light burner on HIGH, immediately turn to LOW setting. Remove knob from valve and using a small flat screwdriver, slowly turn the adjustment screw in the stem, a little at a time (30° to 45°), in either direction, until the flame is approximately 1/4" in height from burner ports.</li> </ol>
<b>Interior light(s) not operating</b>	<ol style="list-style-type: none"> <li>1. Light switch not functioning</li> <li>2. Bulb(s) burned out</li> <li>3. Power supply failure</li> </ol>	<ol style="list-style-type: none"> <li>1. Re-connect external power to grill or contact dealer for replacement.</li> <li>2. Contact dealer for replacement.</li> <li>3. See 1a of <b>Ignition system failure</b> section above and/or replace power supply.</li> </ol>
<b>No power to grill</b>	<ol style="list-style-type: none"> <li>1. Input power source failure</li> <li>2. Power supply failure</li> </ol>	<ol style="list-style-type: none"> <li>1. Check GFCI / circuit breaker.</li> <li>2. See 1a of <b>Ignition system failure</b> section above and/or replace power supply.</li> </ol>

**Table 2**

**Note:** \*Propane tanks are equipped with a safety shutdown device that may cause low or no gas/flame at the burners if operating and lighting instructions are not followed exactly. If you suspect the propane tank safety shutoff is in effect, shut off all burner control valves and the propane tank valve. Then read and follow the LIGHTING INSTRUCTIONS exactly. Lighting instructions are located in the owner's manual. If the problem persists, continue troubleshooting, or contact your local dealer or distributor for assistance.

## WARRANTY

### PETERSON FIRE MAGIC GRILLS AND ACCESSORIES LIMITED WARRANTY

Robert H. Peterson Co. ("RHP") warrants your Fire Magic® grill to be free from defects in material and workmanship.  
 Fire Magic® cast stainless-steel burners, stainless-steel rod cooking grids, and stainless-steel housings are warranted for as long as you own your Fire Magic® grill -- **LIFETIME**. (Except as noted below.)  
 Fire Magic Choice stainless steel tubular burners are warranted for **TWENTY (20) YEARS**.  
 Fire Magic® cast brass burners, brass valves, inner liners, manifold assemblies, and backburner assemblies (except ignition parts) are warranted for **FIFTEEN (15) YEARS**.  
 Fire Magic® Electric Grills, including stainless steel grid, and housings are warranted for **TEN (10) YEARS**.  
 Fire Magic® Infra-red burners, flavor grids, Charcoal stainless steel grills, and Smokers are warranted for **FIVE (5) YEARS**; except for the charcoal pan, charcoal grid, wood pellet screen, thermometer, and ash tray; which are warranted for **ONE (1) YEAR**.  
 Fire Magic® sideburners and all other Fire Magic® grill components (except ignition and electronic parts) are warranted for **THREE (3) YEARS**.  
 Fire Magic® ignition systems (excluding batteries), electronic components (including lights and thermometers), and grill accessories are warranted for **ONE (1) YEAR**.

**A COPY OF YOUR SALES SLIP FOR PROOF OF PURCHASE IS REQUIRED**

This warranty applies to the original purchaser for products which are installed in the United States or Canada and which are operated and maintained as intended for single family residential usage. This warranty is valid only with proof of purchase, shall commence on the date of purchase, and shall terminate (both as to original and any replacement products) on the anniversary date of the original purchase of the product stated on the above schedules.

This warranty covers defects in material and workmanship. This warranty **does not** cover parts which become defective as a result of negligence, misuse, use not in compliance with the Owner's Manual/Installation Instructions, accidental damage, improper handling, improper storage, improper installation, lack of required routine maintenance (as specified in the Owner's Manual/Installation Instructions), electrical damage, local gas impurities or failure to protect against combustibles. Product must be installed (and gas must be connected) as specified in the Owner's Manual/Installation Instructions by a **qualified professional installer**. Modifications to products which are not specifically authorized will void this warranty. Accessories, parts, valves, remotes, etc. when used must be Peterson products or this warranty is void. Warrantied items will be repaired or replaced at Peterson's sole discretion. This warranty **does not** apply to rust, corrosion, oxidation, or discoloration unless the affected part becomes inoperable.

This warranty **does not** cover labor or labor related charges, except as provided by separate specific written programs from the Peterson Co. All repair work must be performed by a qualified professional service person and requires prior approval of Peterson.

Peterson may require the defective product or part to be returned to the factory to determine the cause of failure. Peterson will pay freight charges if the product or part is determined to be defective. This warranty does not cover breakage in shipment from our (Independent) distributor to its customer if the damage is determined to have occurred during that shipment.

This warranty specifically excludes liability for **indirect, incidental**, or consequential damages. Some states and provinces do not allow the exclusion or limitation of incidental or consequential damages, so the above exclusion may not apply to you. This warranty gives you specified legal rights, and you may have other rights that vary from state to state or province.

For additional information regarding this warranty, or to place a warranty claim, contact the R. H. Peterson dealer where the product was purchased.

**TO REGISTER YOUR PRODUCT ONLINE GO TO: [WWW.RHPETERSON.COM](http://WWW.RHPETERSON.COM),  
AND CLICK ON PRODUCT REGISTRATION. THANK YOU FOR YOUR PURCHASE.**

<b>Quality Check</b>			<b>Date:</b> _____		
<b>Burner Orifices</b>	Nat.	L.P.	<b>Leak Test:</b> _____	<b>Model#:</b> _____	
<b>Main:</b>	_____	_____	<b>Burn Test:</b> _____	<b>Serial#:</b> _____	
<b>Back:</b>	_____	_____	<b>Gas Type:</b> <u>Nat. / L.P.</u>	<b>Air Shutter:</b> _____	
<b>Side/Power:</b>	_____	_____		<b>Inspector:</b> _____	
<b>Infrared:</b>	_____	_____			
<b>Other:</b>	_____	_____			