

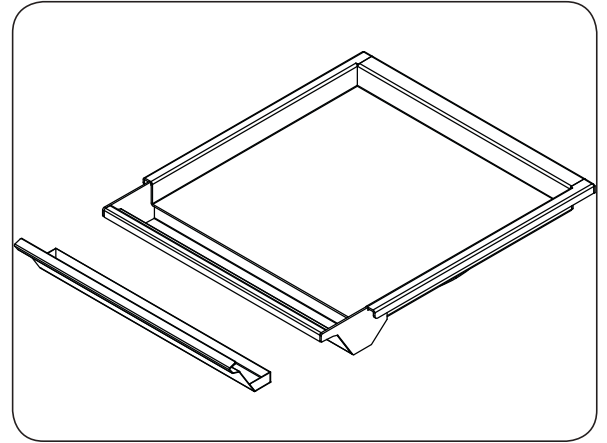

## Stainless Steel Griddle

Model# 3515, 3516



### INSTALLATION AND USE

**CAUTION:** This accessory will remain hot some time after use. Allow time for it to cool before handling and/or cleaning.

This griddle is for installation on Fire Magic Grills and Accessories. To install, follow the steps below.

**CAUTION:** Ensure the appliance is OFF and completely cool.

#### INSTALLATION ON A GRILL

1. Remove cooking grids (2 minimum).
2. Remove flavor grids as needed.
3. Remove zone separators (if applicable).
4. Install/hang the griddle inside the liner. See Fig. 1-1, A.
5. Place the griddle drip tray. See Fig. 1-2.

#### INSTALLATION ON AN ACCESSORY

1. Place griddle directly on cooking grids. See Fig. 1-1, B.
2. Place the griddle drip tray. See Fig. 1-2.

#### Griddle Use

- Before each use, dry the griddle and coat it lightly with vegetable oil or apply a non-stick cooking spray.
- Refer to grill/accessory owner's manual for details on lighting the unit.
- Preheat on HI flame height to bring to temperature. Adjust heat to maintain desired cooking temperature.

Model	Grill/Accessory*	Cooking Area
3515	A830, A540, A430, C430	17" w X 12 1/2" D
3516	E1060, A/E790, A/E660, A530	17" w X 16 1/2" D

\* Either model is compatible with Power Burner and Double Searing Station

**Table 1 - Models available**

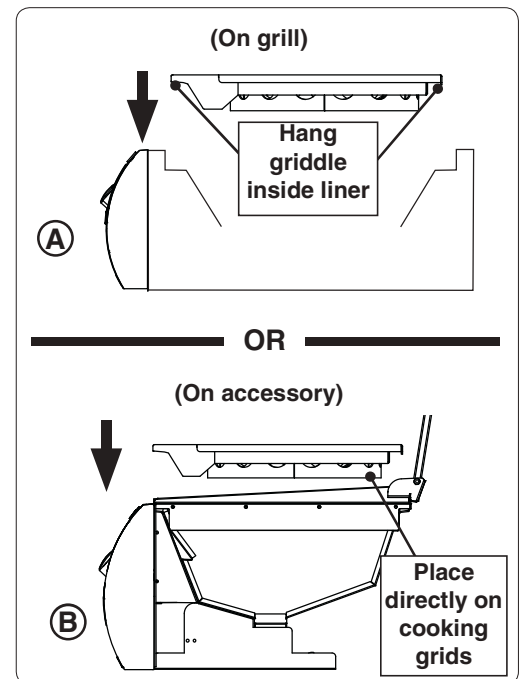

**Fig. 1-1 Install griddle**

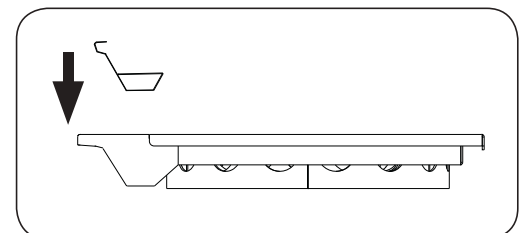

**Fig. 1-2 Install griddle drip tray**

## CARE AND CLEANING

Cleaning the griddle after each use will avoid accumulations of flammable grease, fats, and other debris. Some debris and residue may remain on the griddle.

**Note:** The griddle will discolor due to exposure to high temperatures (this is normal).

**CAUTION:** Allow for the griddle to completely cool prior to cleaning.

- Never flood a hot griddle with cold water. This can cause griddle warping.
- **DO NOT** allow grease to accumulate on the griddle or in the drip tray.
- After each use, clean the griddle:
  - wipe down with a cloth and remove all food residue
  - use a spatula to scrape any excess food into the drip tray
  - use a soapy water mixture and scrub with a scouring pad to help remove cooked-in food
- After each use, carefully remove the drip tray then empty and clean it.
- If any cleaning agents are used, they **MUST** be removed/cleaned with soap and water prior to future use.
- Store griddle inside grill cabinet or in another dry location.